

Acuvim II Series Intelligent Power Meter (Web Accessible)



Revenue Grade with DATA-LOGGING



Email

Data-Logging

Time	Power (kW)	Power (kVA)	Power (kVar)	Power (Hz)	Power (kWh)
10-10-10 00:00:00	100.00	100.00	0.00	50.00	0.0000
10-10-10 00:00:01	100.00	100.00	0.00	50.00	0.0000
10-10-10 00:00:02	100.00	100.00	0.00	50.00	0.0000
10-10-10 00:00:03	100.00	100.00	0.00	50.00	0.0000
10-10-10 00:00:04	100.00	100.00	0.00	50.00	0.0000
10-10-10 00:00:05	100.00	100.00	0.00	50.00	0.0000
10-10-10 00:00:06	100.00	100.00	0.00	50.00	0.0000
10-10-10 00:00:07	100.00	100.00	0.00	50.00	0.0000
10-10-10 00:00:08	100.00	100.00	0.00	50.00	0.0000
10-10-10 00:00:09	100.00	100.00	0.00	50.00	0.0000
10-10-10 00:00:10	100.00	100.00	0.00	50.00	0.0000



Parameter	Maximum	Minimum	Time Stamp
Frequency	0.00 Hz	200.00 Hz	00:00
Max Voltage	0.00 V	200.00 V	00:00
Max Current	0.00 A	200.00 A	00:00
Max Power	0.00 W	200.00 W	00:00
Max kVA	0.00 kVA	200.00 kVA	00:00
Max kWh	0.00 kWh	200.00 kWh	00:00
Max kVar	0.00 kVar	200.00 kVar	00:00
Max Hz	0.00 Hz	200.00 Hz	00:00
Max kWh	0.00 kWh	200.00 kWh	00:00
Max kVar	0.00 kVar	200.00 kVar	00:00
Max Hz	0.00 Hz	200.00 Hz	00:00

Max & Min Record

Metering	Energy and Harmonics	Max and Min #1	Max and Min #2	Alarm Record	SSL
Volts AN	227.58 V	Volts AB	384.19 V	I A	201.57 A
Volts BN	228.90 V	Volts BC	395.33 V	I B	203.41 A
Volts CN	227.61 V	Volts CA	384.72 V	I C	201.89 A
Volts LN Average	227.56 V	Volts LL Average	384.75 V	I Average	202.29 A
Watt A	45873.30 W	VAR A	0.00 Var	VA A	45873.30 VA
Watt B	46153.73 W	VAR B	0.00 Var	VA B	46153.73 VA
Watt C	45960.26 W	VAR C	0.00 Var	VA C	45960.26 VA
Watt Total	137987.29 W	VAR Total	0.00 Var	VA Total	137987.29 VA
Pwr Factor A	1.000	I/N	0.0000 A	Frequency	60.00 Hz
Pwr Factor B	1.000	Imbalance V	0.0%	Dist Watt Total	136.06389 VA
Pwr Factor C	1.000	Imbalance I	0.0%	Dist VAR Total	0.00 kVar

Real Time Metering



ISO9001 Certified



DESCRIPTION

The Acuvim II is a high-end multifunction power meter manufactured by Accuenergy. It is the ideal choice for monitoring and controlling of power distribution systems. Some of the features and electric power parameters available on the compact Acuvim II are:

- True-RMS Measuring Parameter
- ANSI C12.20(0.2 Class) and IEC 62053-22(0.2S Class)
- Power Quality Analysis
- Over/Under Limit Alarm
- Multi Communication Ports (Eg: Ethernet, Modbus)
- Web Server and Email Sending
- Switch Status Monitoring
- Remote Switch Controlling

- Measure Individual Harmonics from 2nd to 63rd(Acuvim IIR)
- Module Design
- Data-Logging

Acuvim II may be used as a data gathering device for an intelligent Power Distribution System or Plant Automation System. All monitored data is available via a digital RS485 communication port running Modbus-RTU Protocol. Ethernet and Profibus DP communication are also options and with new wireless technologies and protocols currently under development, the applications for the Acuvim II meter are limitless.

Acuvim II Series Meter

● Function; ⊙ Option; Blank NA

CATEGORY		ITEM	PARAMETERS	Acuvim II	Acuvim IIR	
METERING	REAL TIME METERING	Phase Voltage	V1, V2, V3, Vlnavg	●	●	
		Line Voltage	V12, V23, V31, Vllavg	●	●	
		Current	I1, I2, I3, In, Iavg	●	●	
		Power	P1, P2, P3, Psum	●	●	
		Reactive Power	Q1, Q2, Q3, Qsum	●	●	
		Apparent Power	S1, S2, S3, Ssum	●	●	
		Power Factor	PF1, PF2, PF3, PF	●	●	
		Frequency	F	●	●	
		ENERGY & DEMAND	Energy	Ep_imp, Ep_exp, Ep_total, Ep_net	●	●
			Reactive Energy	Eq_imp, Eq_exp, Eq_total, Eq_net	●	●
			Apparent Energy	Es	●	●
			Demand	Dmd_P, Dmd_Q, Dmd_S, Dmd_I1, Dmd_I2, Dmd_I3	●	●
	MONITORING	POWER QUALITY	Voltage Unbalance Factor	U_unbl	●	●
Current Unbalance Factor			I_unbl	●	●	
Voltage THD			THD_V1, THD_V2, THD_V3, THD_Vavg	●	●	
Current THD			THD_I1, THD_I2, THD_I, THD_Iavg	●	●	
Harmonics, Individual			Harmonics 2nd to 31st (2nd to 63rd for Acuvim IIR)	●	●	
Voltage Crest Factor			Crest Factor	●	●	
TIF			THFF	●	●	
		STATISTICS	MAX with Time Stamp	V1/2/3, V12/23/13, I1/2/3, Psum, Qsum, Ssum, PF, F, Dmd_P, Dmd_Q,	●	●
			MIN with Time Stamp	Dmd_S, U_unbl, I_unbl, THD V1/2/3, THD I1/2/3, Dmd_I1/2/3	●	●
OTHERS	ALARM	Over/Under Limit Alarm	F, V1/2/3/Iavg, V12/23/13/lavg, I1/2/3/n/avg, P1/2/3/sum, Q1/2/3/sum, S1/2/3/sum, PF1/2/3, PF, U_unbl, I_unbl, Load Type, THD_V1/2/3/avg, THD_I1/2/3/avg, AI, Dmd_I1/2/3	●	●	
	DATA LOGGING	Data Logging 1	F, V1/2/3/Iavg, V12/23/13/lavg, I1/2/3/n/avg, P1/2/3/sum, Q1/2/3/sum, S1/2/3/sum, PF1/2/3, PF, U_unbl, I_unbl, Load Type, Ep_imp, Ep_exp,		●	
		Data Logging 2	Ep_total, Ep_net, Eq_imp, Eq_exp, Eq_total, Eq_net, Es, THD_V1/2/3/avg, THD_I1/2/3/avg, Harmonics 2nd to 63rd, Crest Factor, THFF, K Factor,			
		Data Logging 3	sequence and phase angles, DI counter, AI, AO, Dmd P/Q/S, Dmd I1/2/3			
COMMUNICATION	RS485 Port	Modbus-RTU Protocol	●	●		
TIME	Real Time Clock	Year, Month, Date, Hour, Minute, Second	●	●		
OPTION MODULE	I/O OPTION	Switch Status (DI)	Digital Input (Wet)	⊙	⊙	
		Power Supply for DI	24 Vdc	⊙	⊙	
		Relay Output (RO)	NO, Form A	⊙	⊙	
		Digital Output (DO)	Photo-MOS	⊙	⊙	
		Pulse Output (PO)	By using DO	⊙	⊙	
		Analog Input (AI)	0(4)~20mA, 0(1)~5V	⊙	⊙	
		Analog Output (AO)	0(4)~20mA, 0(1)~5V	⊙	⊙	
	COMMUNICATION	Ethernet	10M/100M, Modbus-TCP, HTTP Webpage, Email	⊙	⊙	
		Profibus-DP	Profibus-DP/V0	⊙	⊙	

I/O Module (Option)

Module Name	Digital Input (DI)	Power Supply For DI (24V)	Digital Output (DO)	Relay Output (RO)	Analog Input (AI)	Analog Output (AO)
AXM-IO1	6	1		2		
AXM-IO2	4		2			2
AXM-IO3	4			2	2	

Communication Module (Option)

Module Name		Spec		
Ethernet	10M/100M self-adaptable, RJ45 Jack HTTP Web page browser	Modbus-TCP/IP Protocol Email sending on time interval or on event		
Profibus	Profibus-DP/VO Input Byte (typical): 32 byte Profibus slave mode, baud rate self-adaptable up to 12M	Output Byte (typical): 32 Byte	EN50170 vol.2 compliance	

APPLICATIONS

- Metering of distribution feeders, transformers, generators, capacitor banks and motors
- Medium and low voltage systems
- Commercial, industrial, utility
- Power quality analysis
- Data Logging

FEATURES

Metering

- Voltage V1, V2, V3, Vlnavg, V12, V23, V31, Vllavg
- Current I1, I2, I3, In, Iavg
- Power P1, P2, P3, Psum
- Reactive Power Q1, Q2, Q3, Qsum
- Apparent Power S1, S2, S3, Ssum
- Frequency F
- Power Factor PF1, PF2, PF3, PF
- Energy Ep_imp, Ep_exp, Ep_total, Ep_net
- Reactive Energy Eq_imp, Eq_exp, Eq_total, Eq_net
- Apparent Energy Es
- Demand Dmd_P, Dmd_Q, Dmd_S, Dmd_I1, Dmd_I2, Dmd_I3

Monitoring

- Power Quality
- Voltage Harmonics 2nd to 63rd and THD
- Current Harmonics 2nd to 63rd and THD
- Voltage Crest Factor
- THFF (TIF)
- Current K Factor
- Voltage Unbalance Factor U_unbl
- Current Unbalance Factor I_unbl
- Max/Min Statistics with Time Stamps

Alarms

Limits can be set for up to 16 indicated parameters and can be set with a specified time interval. If any input of the indicated parameters is over or under its setting limit and persists over the specified time interval, the event will be recorded with time stamps and trigger the Alarm DO output. The 16 indicated parameters can be selected from any of the 51 parameters available.

I/O option module

The E-module® technique was adopted for its flexibility and easy expansion of the I/O function of Acuvim II. A maximum of 3 modules can be used for one meter. Digital input, digital output, pulse output, relay output, analog input and analog output are provided by I/O option module.

Communication

RS485, Industry standard Modbus™ protocol
Module Option: Ethernet module, Profibus-DP module
Dual communication ports

Display

Clear and large character LCD Screen display with white back light
Wide environmental temperature endurance
Display Load percentage, 4 quadrants power and load nature

Outline

Small Size 96x96 DIN or 4" ANSI Round

Data logging

The Acuvim IIR model offers 4MB of onboard data logging memory to be used for historical trending. There are 3 assignable historical logs where the majority of the metering parameters can be recorded. A real time clock allows for any logged events to be accurately time stamped.

TYPICAL WEB PAGE FROM Acuvim II SERIES

DATA LOGGING FROM Acuvim II SERIES

Max & Min Record

SOE Record

Data Logging

Alarm Record

Energy & Harmonics

Acuvim II as Web Server

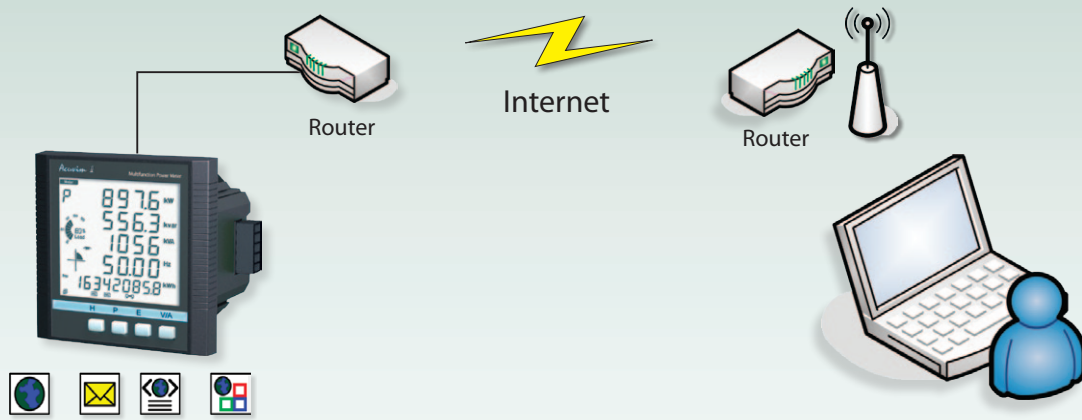

TYPICAL WIRING

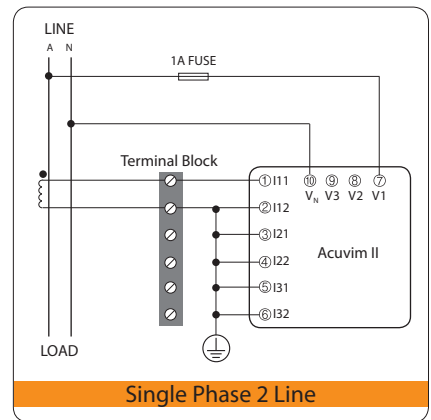
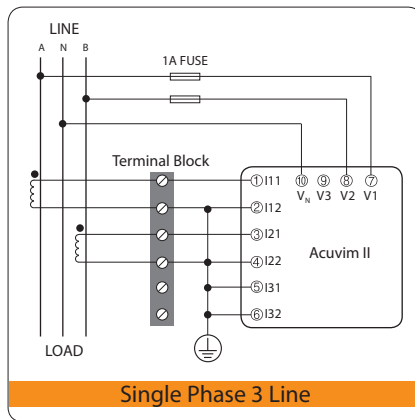
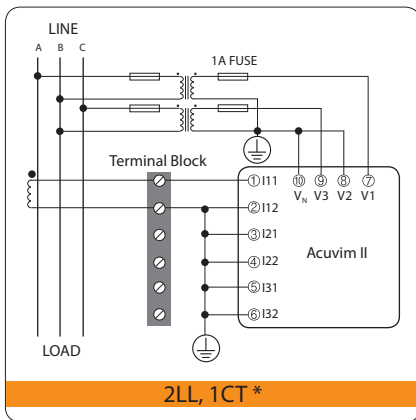
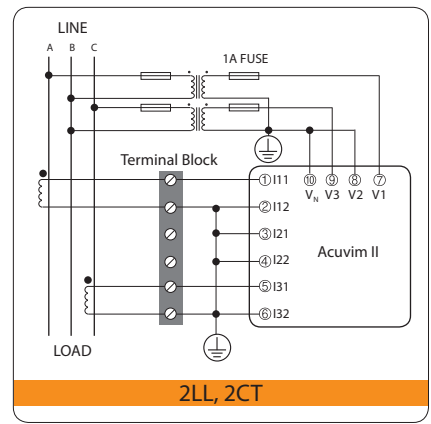
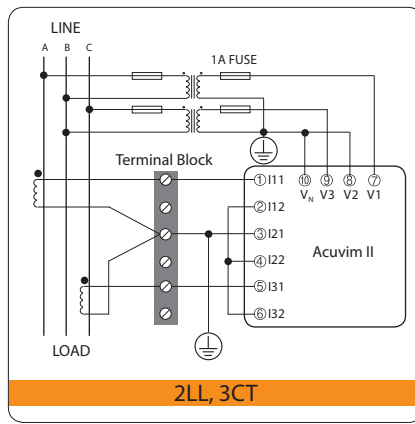
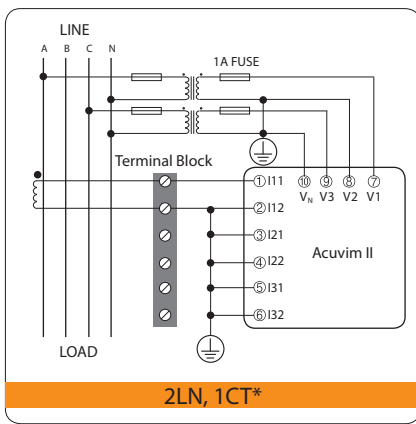
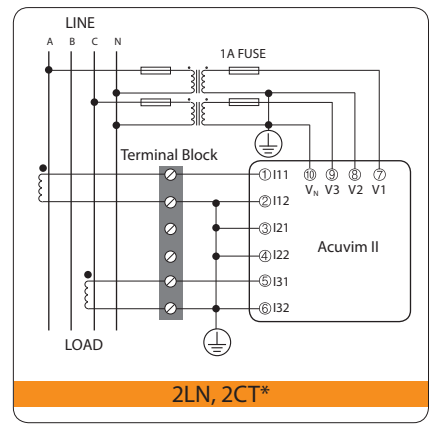
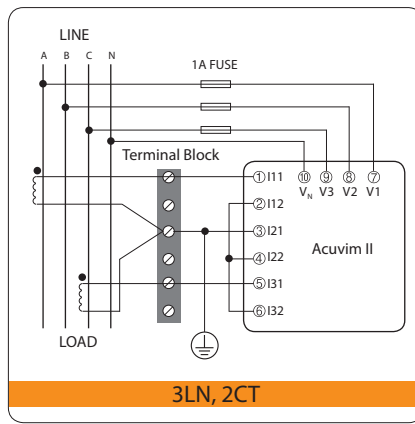
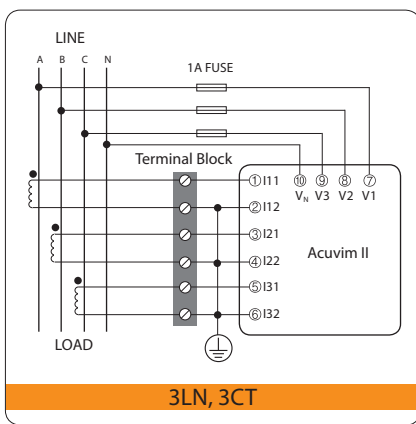

Note: "*" wiring diagram not applicable to Acuvim IIR

SPECIFICATIONS

METERING

Parameters	Accuracy		Resolution	Range	
	Acuvim II	Acuvim IIR			
Voltage	0.2%	0.2%	0.1V	20V~500kV	
Current	0.2%	0.2%	0.001A	5mA~50000A	
Power	0.5%	0.2%	1W	-9999MW~9999MW	
Reactive Power	0.5%	0.2%	1var	-9999MVar~9999Mvar	
Apparent Power	0.5%	0.2%	1VA	0~9999MVA	
Power Demand	0.5%	0.2%	1W	-9999MW~9999MW	
Reactive Power Demand	0.5%	0.2%	1var	-9999MVar~9999Mvar	
Apparent Power Demand	0.5%	0.2%	1VA	0~9999MVA	
Power Factor	0.5%	0.2%	0.001	-1.000~1.000	
Frequency	0.2%	0.2%	0.01Hz	45.00~65.00Hz	
Energy	Primary	0.5%	0.2%	0.1kWh	0-99999999.9kWh
	Secondary	0.5%	0.2%	0.001kWh	0-999999.999kWh
Reactive Energy	Primary	0.5%	0.2%	0.1kvarh	0-99999999.9kvarh
	Secondary	0.5%	0.2%	0.001kvarh	0-999999.999kvarh
Apparent Energy	Primary	0.5%	0.2%	0.1kVAh	0-99999999.9kVAh
	Secondary	0.5%	0.2%	0.001kVAh	0-999999.999kVAh
Harmonics	2.0%	2.0%	0.1%	0.0%~100.0%	
Phase Angle	2.0%	2.0%	0.1°	0.0°~359.9°	
Unbalance Factor	2.0%	2.0%	0.1%	0.0%~100.0%	
Running Time			0.01h	0~9999999.99h	

INPUT

Current Inputs (Each Channel)

Nominal Current	5A ac/1A ac
Metering Range	0~10A ac/0~2A ac
Withstand	20Arms continuous, 100Arms for 1 second, non-recurring
Burden	0.05VA (typical) @ 5Arms
Pickup Current	0.1% of nominal
Accuracy	0.2% full scale

Voltage Inputs (Each Channel)

Nominal Full Scale	400Vac L-N, 690Vac L-L
Withstand	1500Vac continuous 3250Vac, 50/60Hz for 1 minute
Input Impedance	2Mohm per phase
Metering Frequency	45Hz~65Hz
Pickup Voltage	10Vac (30Vac for Acuvim IIR)
Accuracy	0.2% full scale

Energy Accuracy (Acuvim IIR)

Active (according to IEC 62053-22)	Class 0.2S
(according to ANSI C12.20)	Class 0.2
Reactive (according to IEC 62053-23)	Class 2

Harmonic Resolution

Metered Value	Acuvim II: 31st harmonic Acuvim IIR: 63rd harmonic
---------------	---

COMMUNICATION

RS-485 (Standard)

MODBUS RTU Protocol
2-wire connection
Up to 38400 baud rate

Ethernet (Optional)

10M/100M BaseT
MODBUS TCP/IP Protocol
Data Browsing through HTTP
Sending e-mail automatically

PROFI-BUS (Optional)

PROFIBUS-DP/V0 Protocol
Work as PROFIBUS slave, baud rate adaptive, up to 12M
Typical input bytes: 32, typical output bytes: 32
PROFIBUS standard according to EN 50170 vol.2

CONTROL POWER

Universal	AC or DC
AC/DC Control Power	
Operating Range	100~415Vac, 50/60Hz; 100~300Vdc
Burden	5W
Frequency	50/60Hz
Withstand	3250Vac, 50/60Hz for 1 minute
Installation Category III (Distribution)	
Low Voltage DC Control Power (Optional)	
Operating Range	20~60Vdc
Burden	5W

I/O OPTION

Digital Input

Input Voltage Range	20~220Vac/dc
Input Current (Max)	2mA
Start Voltage	15V
Stop Voltage	5V
Pulse Frequency (Max)	100Hz, 50% Duty Ratio (5ms ON and 5ms OFF)
SOE Resolution	2ms

Digital Output (DO) (Photo-MOS)

Voltage Range	0~250Vac/dc
Load Current	100mA (Max)
Output Frequency	25Hz, 50% Duty Ratio (20ms ON, 20ms OFF)
Isolation Voltage	2500Vac

Relay Output (RO)

Switching Voltage (Max)	250Vac, 30Vdc
Load Current	5A(R), 2A(L)
Set Time	10ms (Max)
Contact Resistance	30mΩ (Max)
Isolation Voltage	3000Vac
Mechanical Life	1.5x10 ⁷

Analog Output (AO)

Output Range	0~5V/1~5V, 0~20mA/4~20mA (Optional)
Accuracy	0.5%
Temperature Drift	50ppm/°C typical
Isolation Voltage	500Vdc
Open Circuit Voltage	15V

Analog Input (AI)

Input Range	0~5V/1~5V, 0~20mA/4~20mA (Optional)
Accuracy	0.2%
Temperature Drift	50ppm/°C typical
Isolation Voltage	500Vdc

Power Supply for DI (24Vdc)

Output Voltage	24Vdc
Output Current	42mA
Load (Max)	21DiS

OPERATING ENVIRONMENT

Operation Temperature	-25°C to 70°C
Storage Temperature	-40°C to 85°C
Relative Humidity	5% to 95% non-condensing
Pollution Degree	2

STANDARD COMPLIANCE

Measurement Standard	IEC 62053-22; ANSI C12.20
Environmental Standard	IEC 60068-2
Safety Standard	IEC 61010-1, UL 61010-1
EMC Standard	IEC 61000-4/-2-3-4-5-6-8-11, CISPR 22
Outlines Standard	DIN 43700, ANSI C39.1

DIMENSIONS

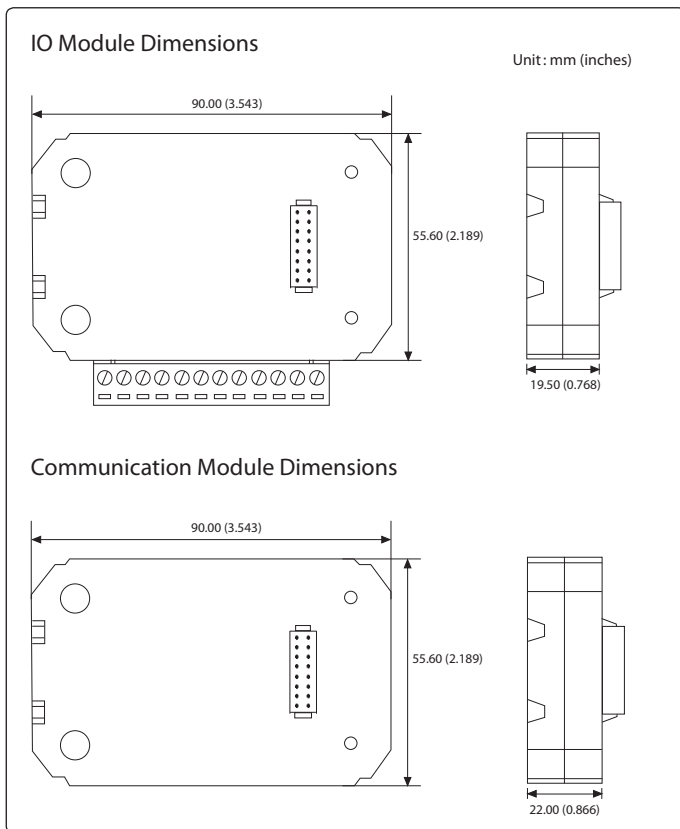
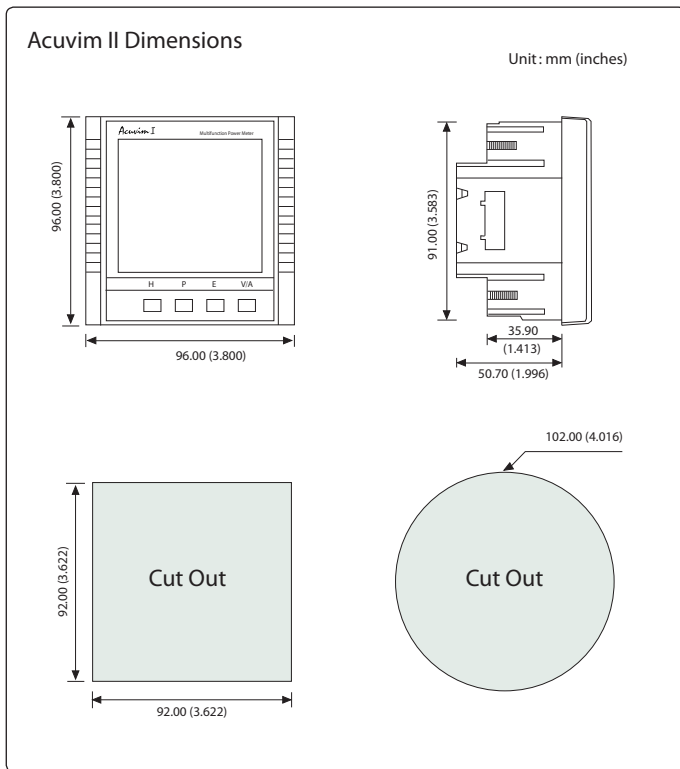

ORDERING INFORMATION

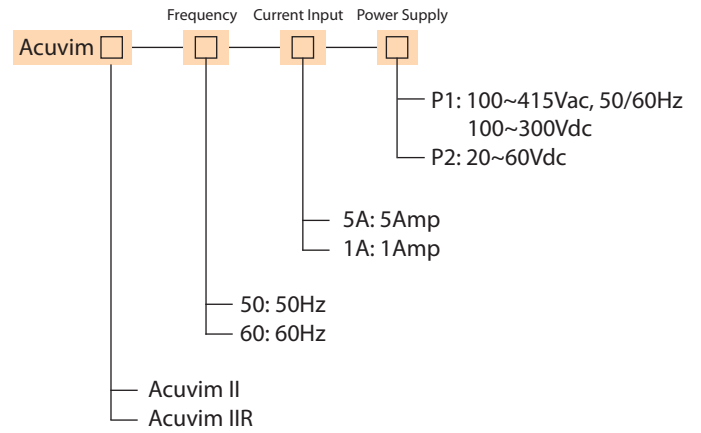

Acuvim II Base Meter Ordering Example: Acuvim IIR - 60 - 5A - P1

I/O Option module

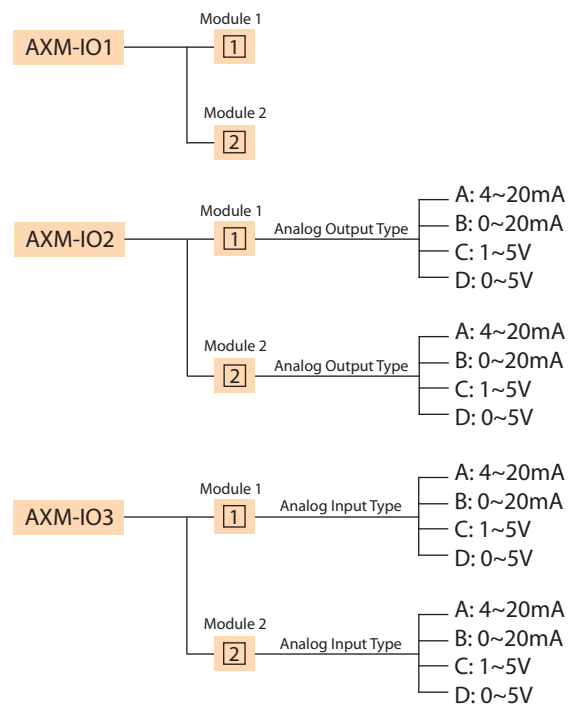

IO Module Ordering Example: AXM-IO2-1A

Communication Option Module

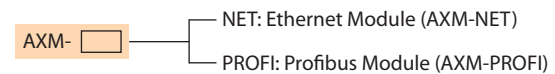

- Note:**
- No more than 2 of the same I/O modules may be attached to the meter (example: Two AXM-IO2). The same two IO modules must be a different component number.
 - A maximum of 3 modules may be attached to the meter. If a communication module is used (example: AXM-NET), it must be installed on the back of the meter FIRST before the other module are attached.



Accuenergy Corporation

Los Angeles-Toronto-Beijing
North America Toll Free: 1-877-721-8908
Web: www.accuenergy.com
Email: marketing@accuenergy.com

Revision Date: Oct, 2009
Document #1040 E1103