

Power Max EM6400 DIGITAL MULTIFUNCTION METER

1 Measure

2 Detect

3 Control



Conzerv Systems Pvt Ltd (formerly Enercon Systems Pvt Ltd)
44P Electronic City Phase II East Hosur Road Bangalore 560 100 INDIA
T+91 80 5118 9700 F+91 80 5118 9729 E contact@conzerv.com
Customer Help Desk 1600 44 0555 (Toll Free All India from BSNL / MTNL lines)
Or Call 080 2852 0604 (Standard Charges Apply)

ISO 9001-2000 Certified

www.conzerv.com

1.1. Customer Service and Support

Customer service and support is available via email at support@conzerv.com. Please include the model, serial number and a description with which we can re-create the problem at our Support Centre. You can shorten this time by also including necessary settings, the wiring diagram and the particular readings, which uniquely identify the problem.

Toll free phone support is available in some countries. For the latest phone number list please visit www.conzerv.com

1.2. Product Warranty

CONZERV warrants all products to be free from defects in material, workmanship and title and will be of the kind and quality specified in CONZERV's written description in the manual. The foregoing shall apply only to failures to meet said warranties, which appear within one year from the date of shipping. During the warranty period, CONZERV will, at its option, either repair or replace any product that proves to be defective. Please see the LIMITED WARRANTY CERTIFICATE provided with the product for further details.

1.3. Limitation of Warranty

This warranty does not apply to defects resulting from unauthorized modification, misuse or use for any reason other than electrical power monitoring.

OUR PRODUCTS ARE NOT TO BE USED FOR PRIMARY OVER-CURRENT PROTECTION. ANY PROTECTION FEATURE IN OUR PRODUCTS IS TO BE USED FOR ALARM OR SECONDARY PROTECTION ONLY.

THIS WARRANTY IS IN LIEU OF ALL OTHER WARRANTIES, EXPRESSED OR IMPLIED, INCLUDING ANY IMPLIED WARRANTY OF MERCHANTABILITY OR FITNESS FOR A PARTICULAR PURPOSE. CONZERV SHALL NOT BE LIABLE FOR ANY PENAL, INDIRECT, SPECIAL OR CONSEQUENTIAL DAMAGES ARISING FROM ANY AUTHORIZED OR UNAUTHORIZED USE OF ANY CONZERV PRODUCT. LIABILITY SHALL BE LIMITED TO THE ORIGINAL COST OF THE PRODUCT SOLD.

1.4. Statement of Calibration

Our instruments are inspected and tested in accordance with specifications published by an independent testing facility. The accuracy and calibration of our instruments are traceable to the National Institute of Standards and Technology through equipment that is calibrated at planned intervals by comparison to certified standards.

1.5. Disclaimer

The information presented in this publication has been carefully checked for reliability; however, no responsibility is assumed for inaccuracies. The information contained in this document is subject to change without notice.

CONTENTS

1.1.	CUSTOMER SERVICE AND SUPPORT -----	2
1.2.	PRODUCT WARRANTY -----	2
1.3.	LIMITATION OF WARRANTY -----	2
1.4.	STATEMENT OF CALIBRATION -----	2
1.5.	DISCLAIMER -----	2
2.	OVERVIEW -----	6
2.1.	PHYSICAL DESCRIPTION -----	7
2.2.	FRONT PANEL -----	7
2.2.1.	<i>The Indicators</i> -----	8
2.2.2.	<i>The Keys</i> -----	8
2.2.3.	<i>Here's an example to try:</i> -----	10
2.3.	POWER MAX EM 6400 TECHNICAL SPECS -----	10
2.3.1.	<i>Standard Measurements</i> -----	11
1.1.1.1.	<i>Accuracy</i> -----	12
2.3.2.	<i>Auxiliary Power Supply</i> -----	12
2.3.3.	<i>Front Panel Display</i> -----	12
2.3.4.	<i>Installation and Input Ratings</i> -----	13
2.3.5.	<i>Environmental Conditions</i> -----	13
2.3.6.	<i>Dimensions and Shipping</i> -----	13
3.	QUICK START GUIDE -----	14
3.1.	KEYPAD OPERATION -----	14
3.1.1.	<i>Auto-Scroll</i> -----	19
1.1.1.1.	<i>FAVOURITE (FAV) key:</i> -----	19
3.2.	SETUP (PROGRAMME) -----	19
3.2.1.	<i>Editing the Setup</i> -----	20
3.2.2.	<i>Energy Integrator</i> -----	25
3.2.2.1.	<i>Integrator Overflow</i> -----	25
3.3.	SUMMARY -----	25
4.	AC POWER MEASUREMENT -----	26
4.1.	THREE-PHASE SYSTEMS -----	26
4.2.	CONSUMPTION AND POOR PF -----	27
4.3.	"3D" KVA MEASUREMENT -----	27
5.	MECHANICAL INSTALLATION -----	28
5.1.	INSTALLATION PROCEDURE -----	30
5.1.1.	<i>Panel Mounting for New Installations</i> -----	30
5.1.1.1.	<i>Location and Mounting considerations</i> -----	30
5.1.1.2.	<i>Usage</i> -----	30
5.1.1.3.	<i>Panel Considerations and Environment</i> -----	30
5.1.1.4.	<i>Viewing</i> -----	31
5.1.1.5.	<i>Mounting</i> -----	31
6.	ELECTRICAL INSTALLATION -----	32
6.1.	AUXILIARY (CONTROL) POWER SUPPLY -----	33
6.2.	PTS AND CTs -----	33
6.2.1.	<i>PT, CT Wiring</i> -----	33
6.3.	VOLTAGE SIGNAL CONNECTIONS -----	34
6.3.1.	<i>PT Connections</i> -----	34
6.3.2.	<i>Selecting the Voltage Fuses</i> -----	34
6.4.	CURRENT SIGNAL CONNECTIONS -----	34
6.4.1.	<i>CT Connections</i> -----	35
6.4.2.	<i>CT Polarity</i> -----	35

6.4.3. CT Connection Reversal -----	36
6.5. SETUP – SYSTEM TYPE-----	36
6.6. PHASE LABELS-----	36
6.7. CONNECTION DIAGRAMS -----	36
6.7.1. Power Max EM 6400 Rear Panel-----	36
6.7.2. Three Phase 3 Wire Delta-----	37
6.7.3. Three Phase 4 Wire Star (Wye) -----	38
7. COMMUNICATION INSTALLATION -----	39
7.1. RS-485-----	39
7.2. REPEATERS -----	40
7.3. FACTORY SETTINGS -----	41
7.4. MODBUS REGISTERS -----	41
1.1.2. PHASE LABELS -----	42
7.4.1. Parameters not available on Display-----	42

Blank pages for notes

2. OVERVIEW

The Power Max EM 6400 series of smart instruments offer comprehensive Three-Phase Electrical Instrumentation and load management facilities in a compact and rugged package.

To get the best out of your investment, we suggest that you take a few moments to review this Manual. This Chapter contains the main operating instructions. The remaining Chapters explain the Installation and Setup steps before the Meter is ready for use.

The Power Max EM 6400 is a universal meter. Before use, please programme the SYS (measurement system configuration), PT and CT ratios through the front panel keys. Otherwise, it will read your system incorrectly. Other settings such as communication parameters must also be programmed as needed.

CONZERV stands behind your Power Max EM 6400 products with complete User Support and Service. If the need arises, please do not hesitate to contact us at support@conzerv.com.



Figure 2.1: The Power Max EM 6400 Multi-function Load Manager

2.1. Physical Description

FRONT: The front panel has 3 rows of 4 digits / characters each, with auto scaling “K” kilo, “M” Mega and “-” minus indications. The “kilo” and “Mega” indications lit together show Giga readings. Five smart-keys make navigating the parameters very quick and intuitive for viewing data and configuring (Setup) the Power Max EM 6400.

REAR: The voltage and current terminals and the communication port are located on the back of the meter. **CAUTION: These contain hazardous voltages during operation and must be operated only by qualified and authorized technicians.**

2.2. Front Panel

The front panel contains the following indicators and controls:

- Three rows of display, 4 digits each that display three rms parameters simultaneously, or one Energy Parameter. The displayed readings update every second.
- For each row: Kilo, Mega (Kilo + Mega = Giga) indicator and a Negative (-) indicator.
- Five keys to scroll through the display page.

The Power Max EM 6400 solves the problem of tiny cluttered indicators by prominently displaying the parameter name right on the large readouts. For the first time in a Panel Meter, the Parameter Name is as clearly readable as the value. The name will be displayed for 2 seconds as well as each time you press a key and then the Value for 8 seconds. This method also allows programmable Phase Labels in the Power Max EM 6400 products. You can choose from 123 (Factory setting), Abc, ryb, Pqr, or rSt.



Figure 2.2: The Power Max EM 6400 front panel with display and keypad

2.2.1. The Indicators

Table 2.1: Kilo, Mega and Negative Indicators

M	<p>Mega: When lit, indicates that the reading is in Mega, (10^6). 10,000 K is shown as 10.00 M. 1.0 M is displayed as 1000 K.</p> <p>When Kilo and Mega are both glowing, the reading is in Giga (10^9). 10,000 M is shown as 10.00 G. 1.0 G is shown as 1000 M.</p>
-	<p>Neg: - When lit, indicates that the reading is negative Per IEEE 100 and industry standard practice by meter-men, the following are Negative:</p> <ul style="list-style-type: none"> • With Forward Flow of Watts: Capacitive (Leading) VARs and PF. • With Reverse Flow of Watts: Inductive (Lagging) VARs and PF and Watts.
K	<p>Kilo: When lit, indicates that the reading is in Kilo (10^3). 10,000 is displayed as 10.00 K. 1.0 K is shown as 1000.</p>

Table 2.2: Giga, Mega (M), Kilo (K) and Decimal Point Scaling

RmS Reading	Indicator
Less than 0.001	K, M OFF, displays “0.000”
Less then 9999	K, M OFF
Above 9999	K ON, M OFF
Above 9999 k	M ON, K OFF
Above 9999 M	Giga (K + M indicators ON)
Upto 9999G	Giga
Above 9999G	Display shows “Hi” for positive numbers and “Lo” for negative numbers





RmS readings are four digits. Energy readings have eight digits, including four additional fractional digits. The maximum number the Meter handles is 9,999 G for RmS and Energy values.

This means that the Energy readings of the meter will overflow at 3 values of kWh or kVAh (selectable through set up) depending upon the PT and CT ratios programmed. See Table 3.4 “[Integrator Overflow Value](#)”

2.2.2. The Keys

Operating the meter is easy using the five smart keys to navigate through the [Keypad Operations Table](#). The Display Pages “expand” as you go right, much like the directory or Explorer “tree” displayed on any computer. **The display shows where you’re headed.**

Table 2.3: The Key pad operation table

	<p>Right Key:</p> <ul style="list-style-type: none"> • Go forward into sub-parameter pages. • During Edit Setup values, select next (right side) digit.
	<p>Left Key:</p> <ul style="list-style-type: none"> • The Opposite of the Right key. • Go Back towards to the Main Parameter Pages. Going Left past “PROG” requires Code entry to enter Main Menu (Setup and Clear) • During Edit Setup, selects previous (left side) digit • Exits from Edit mode, back to the Main Menu.
	<p>Up Key:</p> <ul style="list-style-type: none"> • Scroll Up through Display Pages at the same level, within the same Function. • Continuous pressing for 3 seconds initiates limited Auto-scroll (within the same Function). Press any key to return to manual scrolling. • While editing, increases the value of the blinking digit during Edit. Typically while changing the Meter Setup settings.
	<p>Down Key:</p> <ul style="list-style-type: none"> • The Opposite of the Up key. • Scroll Down through other Display Pages at the same level, through all functions. • Continuous pressing for 3 seconds initiates the Full Auto-scroll mode, through all functions. Press any key to return to manual scrolling. • While editing, decreases the value of the blinking digit during Edit.
	<p>Favourite (FAV) Key:</p> <ul style="list-style-type: none"> • The FAV key scrolls through the following pages: RmS (Home page), VLL, A, F VLN, A, F VA, W, VAR W,VAR, PF PF1, PF2,PF3 , V⁰₁,V⁰₂,V⁰₃ A⁰₁, A⁰₂, A⁰₃ VA.d, R.d, t.r, md, hr VAh Wh R.VAh R.Wh t.VAh t.Wh. This gives simple one-touch access to the most commonly used parameters, even for unskilled operators. “One Touch” does not operate in the Setup (Programme) Mode. • If you’re lost, the FAV key is a quick way to get back to the RmS home page. • Continuous pressing for 3 seconds initiates Auto-scrolling through the above FAV pages. • During the power up, if the FAV key is pressed, meter will go in to set up mode. This is the simplest way to enter in to the setup.

The parameter name is displayed every 9th second for 2 seconds, as well as the first time you press a key. **At this point press the next key immediately to scroll to the next page you want to see. If you are not sure which page you’re watching, one press of any key will immediately identify the name. On pressing the key again immediately takes you to the next page.**

The Meter Menus and Displays are organized as below. Navigating with the Power Max EM6400 is very easy and intuitive. For full details, see the [Keypad Operations Table](#) and the [Meter Function Map](#). The left-most column (Run, CLR, SEt) constitutes the “Main Menu”. Press the key in the direction you want to go. **Display shows where you’re headed.**

Press the key that takes you in the desired direction. You can't cross the thick boundary.

Table 2.4: Menu and Display Map

	Run ▶	◀ PROG		
▲	Main Menu	RmS	V, A, F	V1, V2, V3
				A1, A2, A3
		IntG	VAh	
			Wh	
	CLR			
▼	SEt	V pri		

2.2.3. Here's an example to try:

When you switch on a factory fresh meter, it starts at the "RmS" page, circled "1" in the diagram below. This will be our "Home Page".

From here, to now go to the VAh Energy Page, circled "3" in the diagram below:

1. Start at "RmS"
2. Go Down ▼ to "IntG" and
3. Go Right ▶ to "VAh"

There are no complicated key sequences, since the grouping of parameters is intuitive. The keys always do what they say, under all modes.

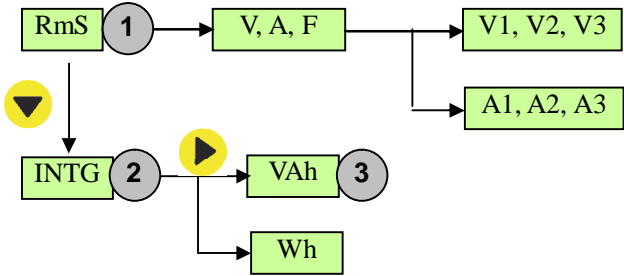

Figure 2.3: Getting Around- an Example

A complete Keypad Operations Map appears in the next chapter. "Run" constitutes the Main Menu, along with "CLR" and "SEt", not shown above, but evident in the left-most "Main Menu" ("Run", "CLR", "SEt") column. To get into the Main Menu you first need to enter a code.

2.3. Power Max EM 6400 Technical Specs

The Power Max EM 6400 Series is a high-accuracy, low cost, ultra-compact, power and energy meter that offers ISO 9000 quality, accuracy and functional flexibility and MODBUS RTU communications capability. The standard unit flush-mounts in a DIN 96 cutout.

The Power Max EM 6400 Series is designed for retrofit application such as replacement of existing analog meters and is also usable as a stand-alone meter in custom panels, PDUs, switchboards, switchgear, UPS's, generator sets, MCCs systems etc.

The Power Max EM 6400 Series (except EM 6459) provides easy communication to PLCs, DCS, BMS and other systems through the use of Modbus RTU communications on RS 485, isolated to 2kV for 1 minute, from other circuits.

The Power Max EM 6400 Series of products are configurable and programmable through the front panel.

Measures true rms electrical parameters. 1 Second update

Wh accuracy : Class 1.0 as per IEC 62052-11 and 62053-23, class 0.5 is optional as per IEC 62052-11 and 62053-22 and ANSI C12.20.

Impulse: 6 kV IEC 60060 1.2 μ S/50 μ S.

Fast Transient: >2kV IEC 61000-4-4 Level 3

ESD IEC 61000-4-2

Emission meets CISPR 22

Power 4 Quadrant, Energy 2 Quadrant. Provides 3D power computation for kVA

2.3.1. Standard Measurements

The Power Max EM 6400 can measure, locally display and remotely transfer over MODBUS RTU, the following electrical parameters over the input range with an accuracy of Class 1.0 or better for Volts and Amps, Power and Energy functions, Class 0.5 is optional:

True rms voltage: phase-to-neutral and 3-phase average.

True rms voltage: phase-to-phase and 3-phase average.

True rms current: per phase and 3-phase average.

Real Power and Energy.

Reactive Power and Energy.

Power Factor.

Frequency.

The Power Max EM 6400 provides all single phase (per-phase) Real, Apparent, Reactive Power and Power Factor values. Positive (Inductive) and Negative (Capacitive) Reactive Energy is separately accumulated for Lead / Lag analysis.

1.1.1.1. Accuracy

Table 2.5: Accuracy Table
Class 1.0 (standard) and Class 0.5 (ordering option)

Measurement	Accuracy	
	Class 1.0	Class 0.5
• Voltage LN, per phase	1.0	0.5
• Voltage LL, per phase	1.0	0.5
• Voltage LN, avg	1.0	0.5
• Voltage LL, avg	1.0	0.5
• Amp, per phase	1.0	0.5
• Amp, avg	1.0	0.5
• Amp, Phase Angle per phase	2°	1°
• Frequency	0.1	0.1
• Real Power, (kW) Per Phase and Total	1.0	0.5
• Reactive Power, (kVAR) Per Phase and Total	2.0	1.0
• Apparent Power, (kVA) Per Phase and Total	1.0	0.5
• Power Factor per phase and average	1.0	0.5
• Active Energy, (kWh) Import/Export	1.0	0.5
• Reactive Energy, (kVARh) (Ind / Cap)	2.0	1.0
• Apparent Energy, (kVAh)	1.0	0.5

- Note 1: Additional error of 0.05 % of full scale for meter input current below 200 mA.
- Note 2: PF error limit is same as W error limit in %.

2.3.2. Auxiliary Power Supply

The meter needs a single-phase ac or dc **Control supply** to power its internal electronics.
Auxiliary supply voltage: 80 to 270 V ac or 100 to 270V dc.
Burden (load) < 3 VA (auxiliary supply).

2.3.3. Front Panel Display

- Brilliant 3 lines, 4 digit (digit height 14.2 mm) per line, **LED display** with auto scaling capability for Kilo, Mega and Giga.
- The display provides the user access to all phase Voltages (phase to neutral and phase to phase), Currents (per phase and total), Watts, VARs, VA, Power Factor, Frequency and kWh, kVAh and kVARh.
- The Power Max EM 6400 displays total volts, amps and frequency simultaneously.
- Easy set up through keys located on the faceplate for common configuration parameters.
- Password protection on setup parameters.

2.3.4. Installation and Input Ratings

- Auto-ranging voltage inputs should allow direct connection up to 500 VLL ac systems (no PTs required up to 500 VLL phase to phase).
- Supports (field configurable) direct 4-Wire Star (Wye), 3-Wire Star (Wye), 3- Wire Delta configurations and single phase via Star (Wye) Phase 1.
- 3-phase voltage and current inputs
 - Volts: 80 to 500 Phase-Phase,
 - Amps: 50 mA to 6 A, Overload: 10 A continuous, 50 A for 3 seconds
 - Field configurable for 5 A or 1 A secondary CTs
 - Burden (Load): Less than 0.2 VA per Volt / Ampere input
 - Frequency: 50 / 60 Hz (45 to 65 Hz)

2.3.5. Environmental Conditions

- Sealed dust-proof construction. Meets IP51 for the front panel
- Temperature Operating: – 10 to 60 °C, (14 to 140 °F)
Storage: – 25 to 70 °C, (-13 to 158 °F)
- Humidity : Below 5% to 95%, non-condensing

2.3.6. Dimensions and Shipping

- Basic unit installed depth 80 mm behind bezel with **92x92** mm panel cutout, flush mount. The Protection cover affixed over the rear Terminal Block extends the depth to 82 mm.
- Bezel dimension 96 x 96 mm. Panel Cutout **92 x 92** mm
- Weight 400 gms approx Unpacked, 500 gms approx Shipping
See Chapter 5: Mechanical Installation.

3. QUICK START GUIDE

This Chapter shows at a glance, how to view the following pages:

- Viewing Three-Phase Total values
- Viewing Per-phase Values
- Viewing Energy Values (IntG)
- Clearing (Resetting) Energy Values
- Setting-up (Programme) the meter before use.

The Power Max EM 6400 displays:

- **Voltage:**
Three voltage measurements Line-to-Line: 1-2, 2-3, 3-1 and Average,
Three voltage measurements Line-to-Neutral: 1-4, 2-4,3-4 and Average.
- **Current:** Three current measurements phase-wise: 1, 2, 3, one average current of all three phases and three current phase angles A°_1 , A°_2 , A°_3 with respect to the corresponding Voltage Line-Neutral vector.
- **Frequency:** Measured from whichever phase is active.
- **Power:** VA, W and VAR. Per phase and Total. PF per phase and 3phase. Per-Phase W readings provide a quick CT Polarity Check. A negated W phase reading indicates CT reversal.
- **Energy:** VAh, Wh, +VARh (Ind), -VARh (Cap), Run Hrs, On Hrs, Supply Interruptions (outage)
- **Kilo, Mega, Giga** [indication](#) for the above parameters.

3.1. Keypad Operation

Table 3.1 shows a complete Map of all the Key Functions. Next Figure 3.1 shows a flowchart of Key Operations. Look at the shaded left half, titled “Name”. Then, follow these simple steps:

- First take a quick look at [what the Keys do](#). Try the simple [example](#).
- Now, try getting around to other parameters, by moving Up, Down, Right and Left. The readings are organized as Display Pages to the Right of “RmS” and “IntG”.
 - The “Kilo”, “Mega” and “Negative” [Indicators](#) are automatic. “Kilo” and “Mega” light up together to show “Giga”.
- You cannot To go Left into the Main Menu (“Run”) unless you enter an entry Code- See Table 3.1 Note 1
- Once in the Main Menu (“Run”), you can go Down to “CLR” or “SEt”. Going right though the “CLR” page allows you to clear the Integrator. Similarly, keep going right through “SEt” to programme the meter settings. When done:
 - Go Left all the way back to the Main Menu
 - Go Up to “Run”
 - Go Right into RmS to view the Display Pages again.

Table 3.1: Meter Function Map

	◀	Code Note 1.	Name ▶			Description
	Run	PROG				
▲		RmS Start Here	V LL A F	V 12 23 31	V LL = A = F =	VLL: Voltage, phase to phase Avg. V 12 = Voltage, rms phase 1 to phase 2 V 23 = Voltage, rms phase 2 to phase 3 V 31 = Voltage, rms phase 3 to phase 1 A: Current, Average F: Frequency.
				V 1 2 3	V 1 = 2 = 3 =	Voltage, rms phase 1 to Neutral Voltage, rms phase 2 to Neutral Voltage, rms phase 3 to Neutral
			V Ln A F	A 1 2 3	V Ln = A = F =	VLn: Voltage, phase to Neutral, Average. A: Current, phase wise, Average. A 1 = Current, rms phase 1 2 = Current, rms phase 2 3 = Current, rms phase 3 F: Frequency in Hertz.
				A ^o 1 2 3	A ^o 1 = 2 = 3 =	Current, Phase Angle of phase 1 in degrees. Current, Phase Angle of phase 2 in degrees. Current, Phase Angle of phase 3 in degrees.
▼			VA W VAR.	VA 1 2 3	VA = W = VAR =	VA: Volt-amperes, Total. VA 1 = Volt-amperes, phase 1 VA 2 = Volt-amperes, phase 2 VA 3 = Volt-amperes, phase 3 W: Watt, Total VAR: VAR, Total.
▲			W VAR PF	W 1 2 3	W = VAR = PF =	W: Watt, Total. Note : "-" Watts = reverse current W 1 = Watts, phase 1 W 2 = Watts, phase 2 W 3 = Watts, phase 3 VAR: VAR, Total PF: Power factor, Average.
				VAR 1 2 3	VAR .1= 2= 3=	VAR, phase 1. VAR, phase 2. VAR, phase 3. Note : "-" Indicates Lead (Capacitive) VAR.
▼				PF 1 2 3	PF 1 = 2 = 3 =	Power factor, phase 1. Power factor, phase 2 Power factor, phase 3. Note: "-" Indicates Lead (Capacitive) Power factor.
		thd	V ^o ₀₁ 2 3		V% .1= 2= 3=	Voltage thd, Phase 1, Total Harmonic distortion, Phase 1 Voltage thd, Phase 2, Total Harmonic distortion, Phase 2 Voltage thd, Phase 3, Total Harmonic distortion, Phase 3
			A ^o ₀₁ 2 3		A% .1= 2= 3=	Current thd, Phase 1, Total Harmonic distortion, Phase 1 Current thd, Phase 2, Total Harmonic distortion, Phase 2 Current thd, Phase 3, Total Harmonic distortion, Phase 3
		dm	VA.d R.d t.r		VA.d = R.d = t.r =	VA demand (W.d= W demand, selectable through setup) Rising demand Time remaining

			md hr		md = hr =	Maximum demand On hour at which the Maximum demand has occurred
▲		IntG	VA.h		VA.h =	Volt-ampere-hours.
			W.h		W.h =	Watt-hours. If watts is negative, VA.h, W.h, VAR.h, -VAR.h do not Integrate.
			VAR.h		VARh =	VAR-hours, Inductive.
			-VARh		-VARh=	Negative VAR-hours, Capacitive.
			run.h		run.h =	Run hours. Total hours the Load was On. Accumulates when current is present.
▼		REV	R.VAh		R.VAh =	Volt – ampere hours (export)
			R.Wh		R.Wh =	Watt-hours (export).
			R.VAR		R.VAR =	VAR-hours, Inductive (export).
			-R.VAR		-R.VAR =	Negative VAR-hours, Capacitive (export).
			R.Run.		R.Run =	Run hours. Total hours the meter was run with reverse energy flow (export)
		tot	t.VAh		t.VAh. =	Total Volt – ampere hours (Import + Export)
			t.Wh.		t.Wh. =	Total Watt-hours (Import + Export).
			t.VAR..		t.VAR. =	Total VAR-hours, Inductive (Import + Export).
			-t.VAR.		-t.VAR. =	Total Negative VAR-hours, Capacitive (Import + Export).
			t.Run		t.Run =	Total Run hours. Total hours the meter was run with current input signals.
			On.h		On.h =	ON hours. Total hours the meter was ON. Accumulates if auxiliary supply is present (irrespective of input signals).
			Intr		Intr =	Auxiliary interruption. Accumulates the auxiliary interrupt.
	CLR	IntG	IntG y / n	▶ to Clear	CLR =	Clear. If "y", Clears all integrator parameters (above) to zero.

▲	SEt		SyS V.PRI V.SEC A.PRI A.SEC LAbL VA.Fn d.SEL d.PAR d.PrD baud Prty Id	StAR 415.0 415.0 5000.0 5.000 123 3d Auto VA 15.00 9600 EVn.1 1.000	▶ to Edit Setting	<p>Choice of values</p> <p>SyS = Power system's configuration* : Star (3E 4V3A), Delta (3E 3V2A)</p> <p>V.PRI = Voltage primary winding(PT)* : Line to Line: 100 V to 999 kV(415.0)</p> <p>V.SEC = Voltage secondary winding(PT)* : Line to Line : 80 to 600 V(415.0)</p> <p>A.PRI = Current primary winding.(CT)* : 1 A to 99 kA (5000.0)</p> <p>A.SEC = Current secondary winding.(CT)* : 1 to 6.5 A. (5.000)</p> <p>LABL = Phase labelling formats. : 123, ryb, rst, Pqr, Abc.</p> <p>VA.Fn = VA function selection : 3d, Arth</p> <p>d.SEL = Demand selection : auto, user *</p> <p>d.PAR = Demand parameter : VA, W</p> <p>d.PRd = Demand period : 5,10,15,20,25,30</p> <p>baud = Baud rate : 1200, 2400, 4800, 9600, 19200.</p> <p>Prty = Parity and Stop bit settings: EVn.1, EVn.2, Odd.1, Odd.2, no.1, no.2</p> <p>Id = RS485 Device ID number: 001 to 247. (Evn.1 = Even. 1 stop bit)</p> <p>*changing these values while the device in use, is not recommended</p> <p>Default set up values are given in bold and italics</p>
		DiaG	Id Baud Prty	1.000 9600 Evn.1		For factory testing only
		dIA2	Mdl. Ver Ver	6400 02.03. 01.00		For factory testing only

KEY FUNCTION MAP NOTES:

1. To Clear Integrated values or Set meter settings, you must first enter the Main Menu.
2. Go Up to “PROG”, then Left to enter the Main Menu. See Map or Table 3.1.
 - You must now enter the Factory Set code of 1000, to proceed.
 - "Code y”, followed by the entry of the Code “1000” is required.
 - To enter the code, edit the blinking digit value up or Down to get “1000”.
 - Keep going Left.
 - Without entering the code, you may view the settings, but you can’t change them.

Within the “SEt” page options, the Factory settings are shown Bold Text in the right side column above.

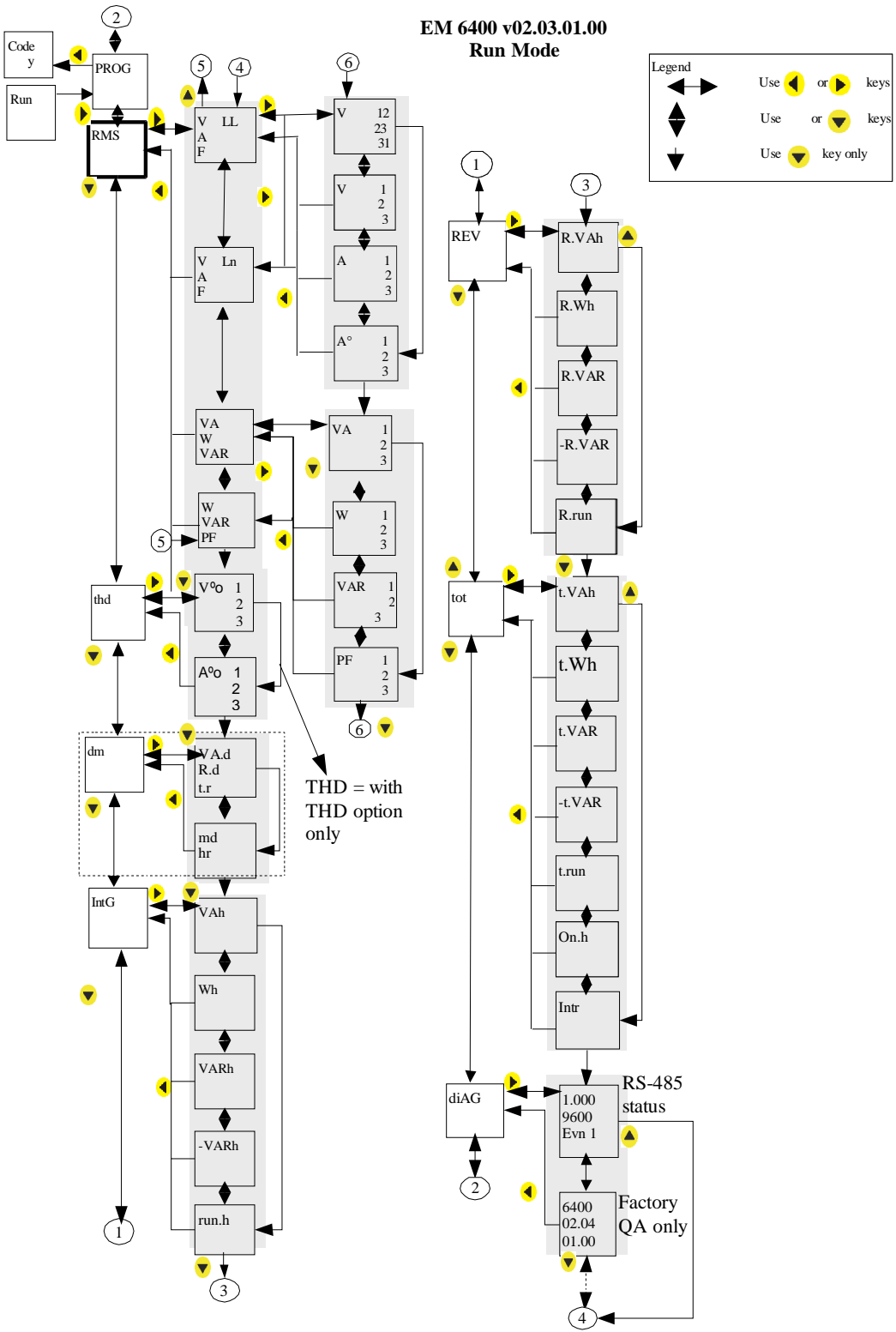

Figure 3.1: The Run Mode Flow chart

3.1.1. Auto-Scroll

Auto-Scroll allows you to monitor a group of Display Pages sequentially, every 5 seconds, without constant key pressing. This is convenient for viewing from a distance. Since the Power Max EM 6400 displays the Parameter Name (1sec) followed by the Value (4 sec) on the same large displays, both are equally readable from a distance. No more squinting at a clutter of parameter indicators.

To enter auto-scroll, go to the desired display page and keep the Up ▲ or Down ▼ key pressed for minimum 3 seconds, then release key. The display flashes “Auto” and then automatically scrolls through other pages at the same level (column in the above table). Press any key to revert to Manual Scrolling.

- The Up ▲ key enters Limited Auto-scroll – within the same Group, e.g. only “RmS” or only “IntG”.
- The Down ▼ key enters Full Auto-scroll- down the entire column of pages.

1.1.1. FAVOURITE (FAV) key:



The FAV key scrolls through the following pages:

'VLL, A, F' 'VLN, A, F' 'VA, W, VAR' 'W, VAR, PF' 'PF1, PF2, PF3' 'V₀₁, V₀₂, V₀₃'
 'A₀₁, A₀₂, A₀₃' 'VA.d, R.d, t.r' 'md, hr' 'VAh' 'Wh' 'R.VAh' 'R.Wh' 't.VAh' 't. Wh'. This gives simple one-touch access to the most commonly used parameters, even for unskilled operators. “One-touch” does not operate in the Setup (Programme) Mode. Optional parameters are with bold characters.

- **If you're lost, the FAV key is a quick way to get back to the RmS home page.**
- Continuous pressing for 3 seconds initiates Auto-scrolling through the above FAV pages.

3.2. Setup (Programme)

The meter must be set (programmed/configured) to match the application settings, before use. Otherwise, the readings will be wrong. All the Setup values can be re-programmed at any time, upon entering “SEt” However, the settings: Sys (Star/wye or Delta), Vpri, Vsec, Apri, Asec critically determine the scaling of measured readings. While the scaling may be used to tune out Instrument Transformer errors, wrong settings will upset the readings of running systems. It is the user's responsibility to ensure that only qualified personnel correctly Set-up the Meter.

Table 3.1a: Entering in to setup

Action	Display	Remarks
From the “RmS” or “IntG” page, go Up ▲ Then go Left ◀. "Code 0" is displayed. "0" blinks.	ProG "Code 0"	The meter is about to enter the Main Menu. "0" blinks. To proceed with Code Entry, we need to enter the Main Menu. • Go Left ◀. Or, to abort and re-enter RmS: • Press ▶. Or, to only view setup, (no edit): • Press ▲ or ▼ to toggle "0" to "1". • Press ◀ to enter Main Menu. "Fail" is flashed, then "Run" is displayed.
To proceed with Code Entry:	"000 0"	The blinking digit indicates the cursor.
The code is Factory Set to 1000. Press ◀ to enter each digit. Three times totally.	"2 000"	We have now entered the Units, Tens and Hundreds digits. The Thousands digit needs to be changed from 2 to 1.
Press ▼ to decrement "2".	" 1 000"	Now the Code of 1000 is almost in.
Press ◀ to enter the Main Menu.	" 0000" "Pass" "Run" Or, "Fail"	Notice that a "0" quickly hides each code-digit you enter. "Run" indicates a successful entry into the Main Menu. Congratulations! If you were not successful, don't despair; you can have another go from the top of this Table. Briefly switching off the Meter will easily return you to the RmS page, the starting point.
Now press ▼ Again press ▼	"CLR" "SEt"	You are at the Setup page.
Press ▶ to get into setup	"SYS" "V.PRI" "V.SEC"	Go ▼ to see other Settings. Go ▶ to see and change their values.
Once you're done, re-trace your path: ◀ and ▲. Remember "Save Y"	"Run"	You're now at the top of the Main Menu. Go ▶. You'll see RmS. You can now go ▶ or ▼ to view all the display pages.

3.2.1. Editing the Setup

First, take a look at the Table 2.3 ([Keypad Operations Table](#)). Locate the Shaded, Bold display pages below.

To enter "SEt" and change a Setting value, the sequence (shown below) is: 1, 2, 3, and 4 along the way, the following must be observed:

- The Password Code must be entered to change the Setup. The code offered will read "0000". Edit (▲, ▼) the blinking Digit to achieve "1000". Press ◀ when done with each digit, to keep moving towards the "Run" page. The Meter accepts each digit entered, but masks it with "0000" so someone watching doesn't steal the password.

After changing the desired Setup values (Step 4), the sequence to get back to the RmS page is: 5, 6, 7, 8.

- Exiting Setup requires you to Save the settings (Step 6). "SAVE Y", press ◀.
To Discard the changes, toggle Up▲ or Down▼ to get "SAVE N" before pressing ◀.

Going forward from 7 (Run) to 8 (PROG) does not require any Code. You go ▶, straight through..

EM 6400 v02.03.01.00

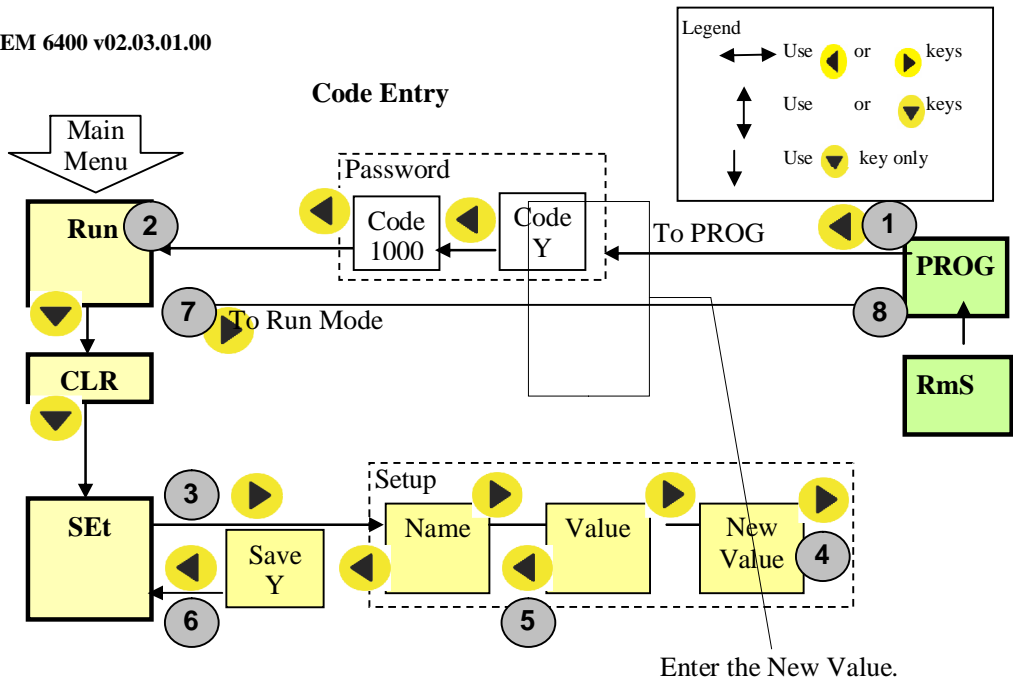

Figure 3.2a: Entering and Exiting Setup

EM 6400 v02.03.01.00

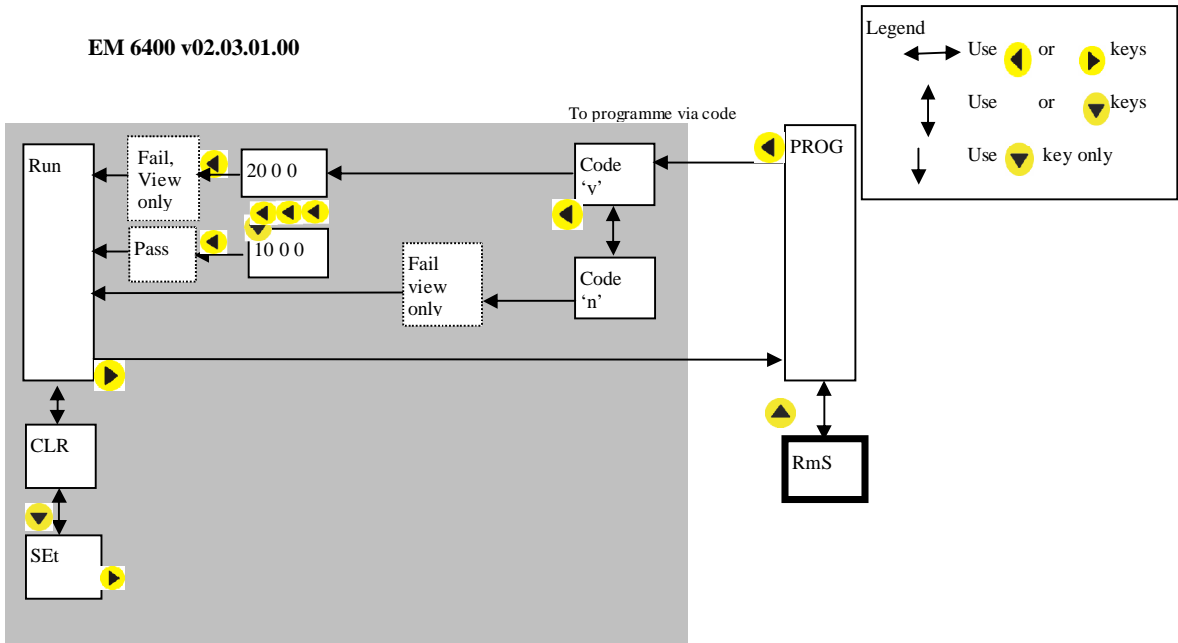

Figure 3-2b: Code entry for Entering Setup

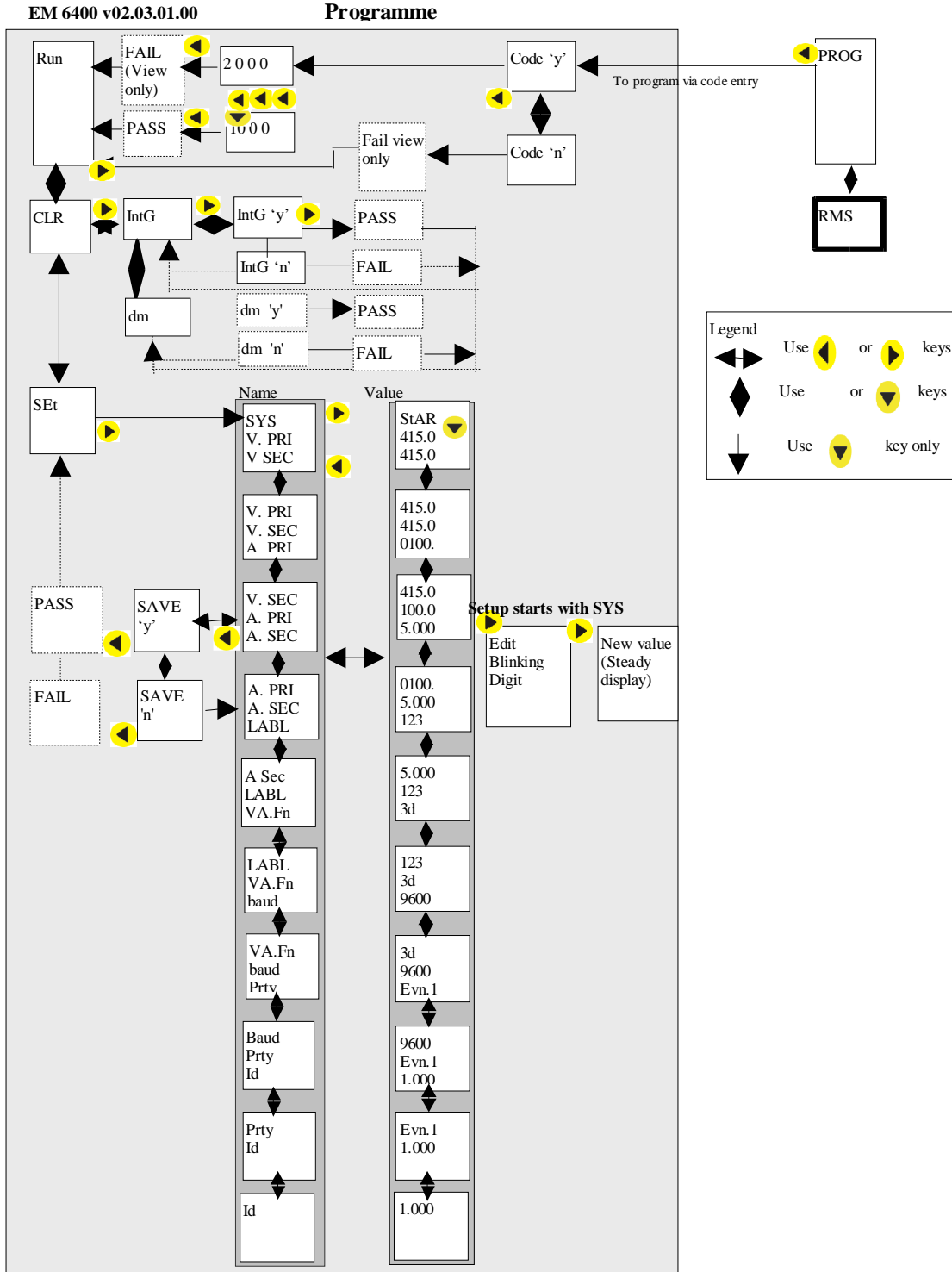

Figure 3.2c: The complete Setup (Programme) menu

Table 3.2: Editing the Setup Values

First, you must enter the Main Menu and reach “SEt” using the previous Table. This example illustrates changing System Mode (SYS) from “Star” to “Delta”.

Action	Display	Remarks
	"SEt"	You're in the Main Menu.
Press ► . Enter Setting	SyS V.PRI V.SEC	Wiring System. Voltage primary. Voltage secondary.
We have now reached SyS (top row) for editing. Press ► to view Value.	"StAR" 415.0 415.0	Wiring System = Star 3E, 4V3A Voltage primary = 415V. Voltage secondary = 415V.
Press ► to edit SyS value. The value blinks.	"StAR" 415.0 415.0	Blinks. Only Top Row is edited Ignore Ignore
Press ▼ to change to Delta 2E.	"dltA" 415.0 415.0	Blinks. (Note: To discard the change: • Press ◀. • Restores the previous value.)
Press ► to accept the value.	"DltA" 415.0 415.0	Steady. Sys is now set to Delta. Press ▼ to scroll down, and ► to change other values.
We're done. Press ◀ to head back.	"SyS" Blinks	
Press ◀ again.	"Save" "y"	NOTE: To discard present changes, press ▼ to show "Save n".
Press ◀ to accept "y" (yes, save)	"PASS" "SEt"	"PASS" flashes and Stores the Setup changes. Now, you're back in the Main Menu and can go ▲ to "Run" and ► to "RmS".

Table 3.3a: Clearing the Energy Integrator and Max Demand (W.h, VA.h, VAR.h, -VAR.h, etc.)

Action	Display	Remarks
Use Table 3.1 to enter the Main Menu. Press ▼ to reach "CLR"	"CLR"	You're in the Main Menu.
Press ► to enter CLR mode.	"IntG"	
Press ► to proceed with CLR	"IntG y"	Clear IntG? Yes! NOTE: ◀ escapes back to Main Menu
Press ► to Clear.	"PASS" "IntG"	"PASS" flashes IntG and Max demand Cleared.
To head back, press ◀	"CLR"	Now, you're back in the Main Menu and can go ▲ to "Run" and ► to "RmS"

Table 3.3b: Clearing only the Maximum Demand

Action	Display	Remarks
Use Table 3.1 to enter the Main Menu. Press ▼ to reach "CLR"	"CLR"	You're in the Main Menu.
Press ▶ to enter CLR mode.	"md"	
Select the parameter ▼ or ▲	"IntG" or "md"	Select which parameter to be deleted
Press ▶ to proceed with CLR	"md █"	Clear md? Yes! NOTE: ◀ escapes back to Main Menu
Press ▶ to Clear.	"PASS" "md"	"PASS" flashes and 'md' cleared and 'md' displayed.
To head back, press ◀	"CLR"	Now, you're back in the Main Menu and can go ▲ to "Run" and ▶ to "RmS"

Clearing the Integrator

EM6400 v02.03.01.00

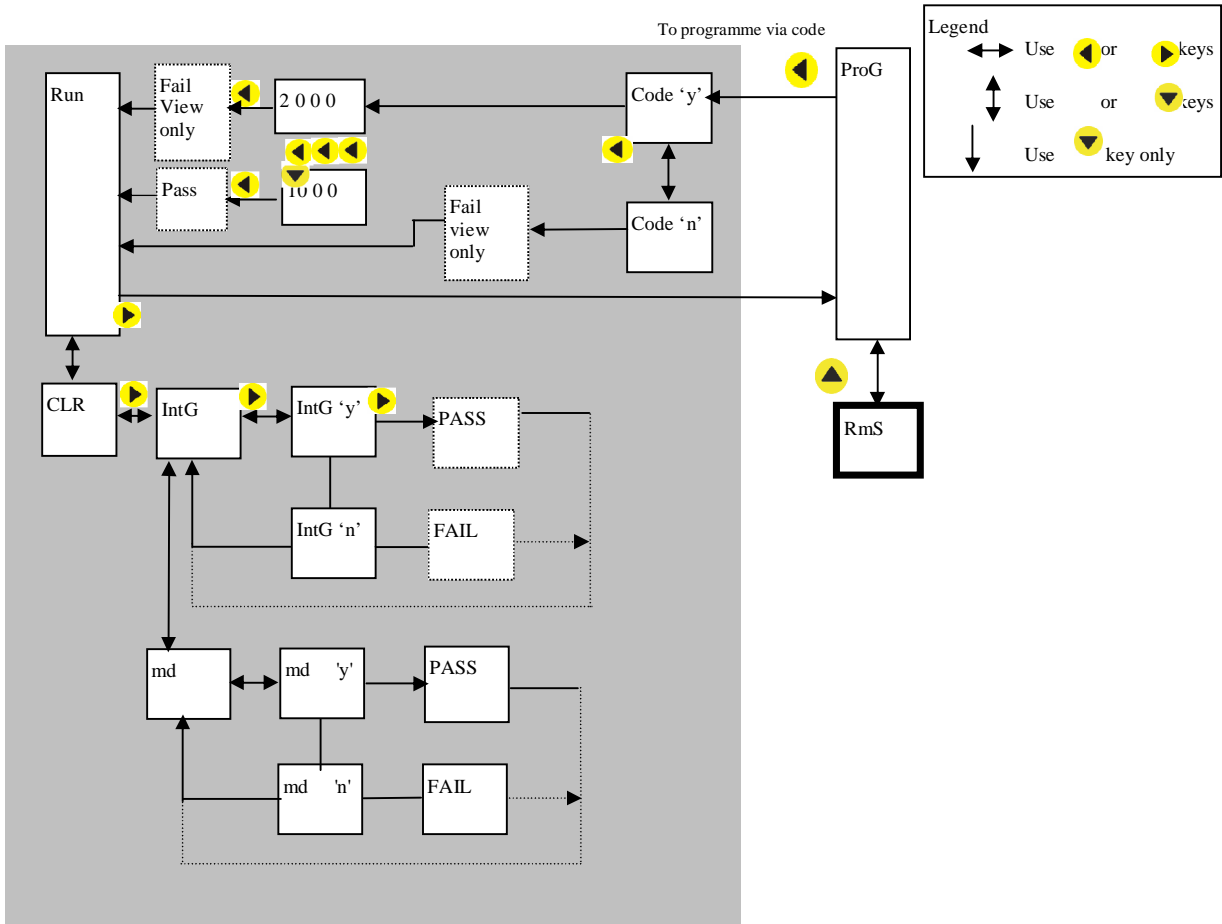

Figure 3.2d: Clearing the Integrator and Demand

3.2.2. Energy Integrator

Your Power Max EM 6400 meter is equipped with Energy Integrator function which provides several parameters for Energy Management: VAh, Wh, VARh, -VARh, run.h (run hours), on.h (on hours), Intr (Interruptions / outages).
A few of these need explanation:

run.h: Indicates the period the Load is ON and has run. This counter accumulates as long as any one Amps phase has more than 10mA through the meter terminal.

on.h: The period for which the meter (supply) is ON.

Intr: Number of Supply Outages, means the number of Auxiliary Supply interruptions. If the meter Auxiliary Supply is from a UPS then the Intr (number of interruptions) will be zero (as long as the UPS stays ON), even if the Voltage Signals did die out from time to time.

3.2.2.1. Integrator Overflow

Your Power Max EM 6400 meter contains a comprehensive “Integrator” to support Energy Management. It accumulates several parameters over time, as explained above. All values are Direct Reading and have a high resolution. This is necessary for accurate energy analysis over short intervals of time. It also means that the readings max out and reset sooner or later as given below. Since the Integrator contains counters for several parameters (VAh, Wh, VARh, -VARh, Run Hours, On Hours, Interruptions), they all reset together whenever any one of them (usually VAh) overflows. This makes energy management calculations such as Average PF very easy.

The maximum number that the Meter handles is 9,999 Giga for RmS and Energy values. The value at which the meter overflows is given below. See Table 3.4 “[Integrator Overflow Period](#)”.

The Overflow Period depends on the Product of the PT Ratio and CT Ratio that you’ve programmed for your application.

$$\text{PT Ratio} * \text{CT Ratio} = \frac{V_{pri}}{V_{sec}} \times \frac{A_{pri}}{A_{sec}}$$

Table 3.4: Integrator Overflow Period

PT Ratio x CT Ratio	Max Reading	Overflow Period (Months)	
		Max	Min
1 to 1.999	9.999x10 ⁶	3.85	1.92
2 to 10.999	9.999x10 ⁷	19.29	3.51
11 to 100.999	9.999x10 ⁸	35.07	3.82
101 to 1000.999	9.999x10 ⁹	35.07	3.82
1001 to 10000.999	9.999x10 ¹⁰	35.07	3.82
10001 to 100000.999	9.999x10 ¹¹	35.07	3.82
Greater than 100001	9.999x10 ¹²	35.07	3.82

3.3. Summary

We have now learnt

1. To operate the Power Max EM 6400 Series products.
2. To configure its Setup and
3. To Clear its Integrator.

4. AC POWER MEASUREMENT

This Chapter describes the following:

- 1. Fundamentals of Three-Phase Measurements

4.1. Three-Phase Systems

A three-phase system delivers higher levels of power for industrial and commercial applications. The three phases correspond to three potential lines. A 120° phase shift exists between the three potential lines.

A typical configuration has either a Delta connection or a Wye (Star) connection (see **Figure 4.1**, below).

In a three-phase system, the voltage levels between the phases and the neutral are ideally defined by $V_1 = V_2 = V_3 = V_{12} / \sqrt{3} = V_{23} / \sqrt{3} = V_{31} / \sqrt{3}$. In practice, there will be some unbalance (difference).

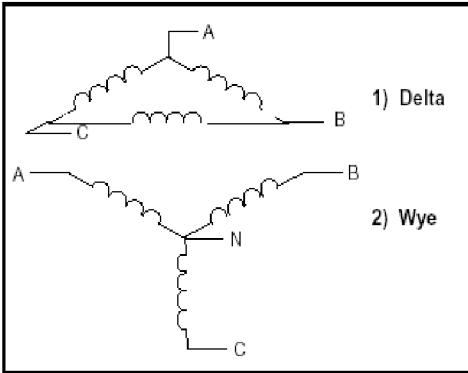

Figure 4.1: Three-Phase System: (1) Delta, (2) Star (Wye)

Voltages between the phases vary depending on loading factors and the quality of distribution transformers.

Power measurement in a poly phase system is governed by **Blondel's Theorem**. Blondel's Theorem states that in a power distribution network, which has N conductors, the number of measurement elements required to determine power is N-1. A typical configuration of poly phase system has either a Delta connection or a Star (Wye) connection (see **Figure 4.2** below).

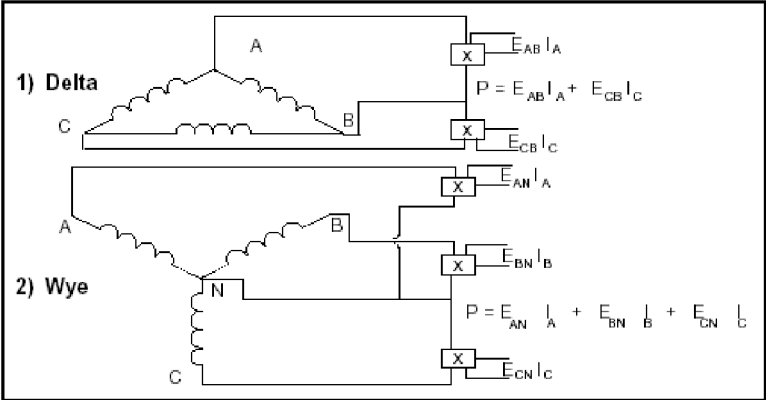

Figure 4.2: Poly Phase System: (1) Delta, (2) Star (Wye)

4.2. Consumption and Poor PF

CONSUMPTION; Wh = W x T, where W = instantaneous power T = time in hours
 The total electric energy usage over a time period is the consumption of Wh.
 Typically, the unit in which consumption is specified is the kilowatt-hour (kWh): one thousand watts consumed over one hour. Utilities use the Wh equation to determine the overall consumption in a billing period.

POOR POWER FACTOR: Results in reactive power consumption. Transferring reactive power over a distribution network causes energy loss. To force consumers to correct their Power Factor, utilities monitor reactive power consumption and penalize the user for Poor Power Factor.

4.3. “3D” kVA Measurement

The Power Max EM 6400 is equipped with 3D Measurement of kVA. This advanced method provides the most accurate and predictable measurement under unbalanced as well as distorted waveform conditions.

However, in case the Power Max EM 6400 needs to match the reading of older or simpler meters, which use the Arithmetic kVA definition, this too is available as a Set-up option.

Table 4.1: VA Function Set up Options

kVA Function	Formula	Other Names	Which one?
3D (Factory setting)	$kVA_{3D} = \sqrt{\sum W^2 + \sum VAR^2 + \sum D^2}$ Where D = Distortion Power per IEEE 100	U, Apparent, Vector kVA	Best, all around
Arth		Arithmetic, Scalar kVA	Good under Low unbalance, to match simpler meters without 3D capability

5. MECHANICAL INSTALLATION

The Power Max EM 6400 is panel-mounted and has reliable, rear-mounted terminal strips rated at 500v. The 92 x 92 mm cut-out and 96 x 96 mm bezel dimensions adhere to DIN 43700.

Depth required behind the Bezel is 80 mm, plus space for wiring. Two side clamps are provided for firm mounting.

CAUTION . . . :

All Installation, wiring and maintenance instructions to be carried out by qualified personnel only.

Please read this and the following chapter completely, before proceeding

These diagrams display the various dimensions of mechanical installations.

SIDE VIEW

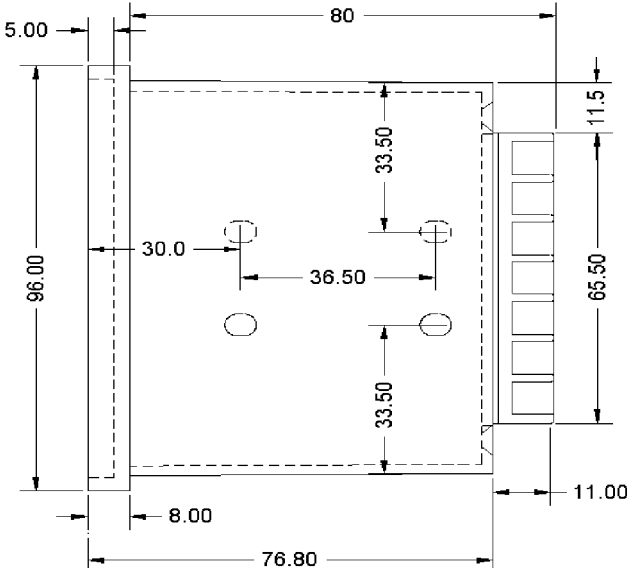

REAR VIEW

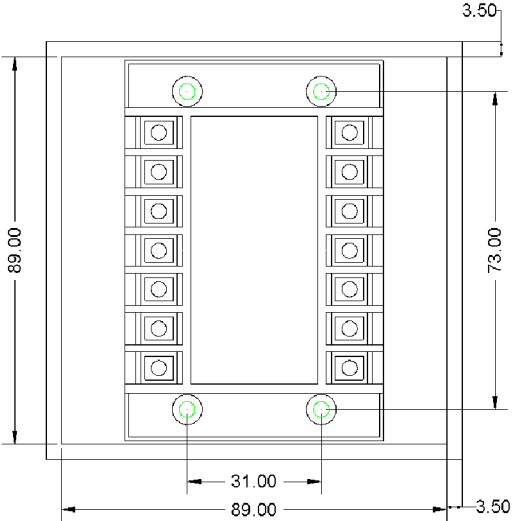

FRONT VIEW



TOP VIEW

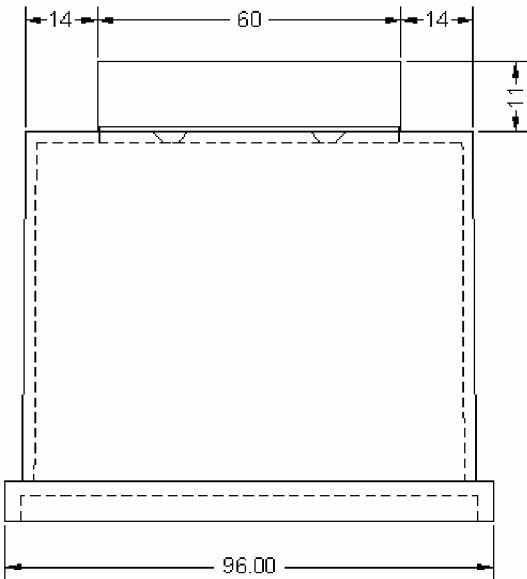

RECOMMENDED CUTOUT

92 x 92 mm

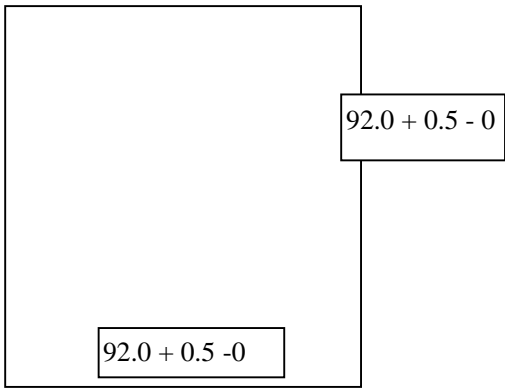

5.1. Installation Procedure

5.1.1. Panel Mounting for New Installations

5.1.1.1. Location and Mounting considerations

DANGER M:

All Installation, wiring and periodic maintenance of the Power Max EM 6400 as well as its associated circuits involve high voltages and currents. While this manual suggests several safety and reliability steps, it must be used in conjunction with the safety codes in force at your location. Failure to practice safe working procedures is likely to cause damage to the installation, severe injury and / or death. All work including handling of electrical circuits during Installation, only qualified personnel must do wiring and periodic maintenance.

Neither CONZERV nor its agents may be held responsible for damage or death arising out of the wiring and / or PT, CT or other external circuits.

The covers of the Power Max EM 6400 should never be dismantled or opened. There are no user-serviceable parts inside. The Power Max EM 6400 contains high-precision components, which require special handling available only at authorized CONZERV service locations. High voltages are likely to be present inside even after the Power Max EM 6400 has been switched off. Opening the covers of the Power Max EM 6400 and/or any attempts to dismantle, service, repair or modify the unit by unauthorized persons may cause severe injury, will damage the unit and will also render CONZERV's warranty void.

5.1.1.2. Usage

First, decide on how the Power Max EM 6400 is going to be used. If you do not already have an Energy Management programme in operation, then your Energy Consultant should be able to help you identify which load(s) offer maximum savings potential. This will help you decide: Which point is to be monitored, where the readings will be viewed from, who must have access to the instrument and how often. For best performance, choose a location, which provides all the required signals with minimum wiring lengths.

5.1.1.3. Panel Considerations and Environment

The Power Max EM 6400 is a high - precision measuring instrument and its operating environment is of utmost importance. For maximum performance, the instrument should be mounted in a dry, dust-free location, away from the heat sources and strong electromagnetic fields. To operate reliably, the following conditions must be met:

Storage Temperature : -25^o to 70^o C, (-13^o to 158^oF)

Operating Temperature: -10^o to 60^o C, (14^o to 140^oF)

Relative Humidity : 5% to 95%, non-condensing.

The Power Max EM 6400 should be separated from other equipment and sufficient space must be provided all around for cooling air to rise vertically past the instrument. The cooling air temperature must be below the specified operating temperature.

The panel or housing, in which the Power Max EM 6400 is mounted, should protect it from dust, moisture, oil, corrosive vapours, etc.

The panel doors must be easily opened to provide easy access to the Power Max EM 6400 wiring for trouble-shooting. Allow clearance if the unit is going to swing out, as well as adequate slack in the wiring. Allow space for terminal blocks, CT shorting blocks, fuses, auxiliary contractors and other necessary components.

5.1.1.4. Viewing

For ease of operation, in the location should be preferably at, or slightly above, eye-level. For viewing comfort, minimize glare and reflections from strong light sources.

5.1.1.5. Mounting

Before Mounting and Wiring, the [Setup procedure](#) (see section 3.2) should have been completed.

The Power Max EM 6400 is panel mountable.

Panel cut-out	92 ^{+0.5} -0 (w) x 92 ^{+0.5} -0 mm (h) DIN 43700
Panel Thickness	0.5 to 4.0 mm
Instrumental Bezel dimension	96 x 96mm
Depth behind Bezel	80 mm. Leave clearance for wires. 82 mm with Terminal Cover
Mounting Clamp Screws	Slotted, 2 nos
Terminal Screws	Combination Phillips and Slotted head

The cut-out should be punched with the proper tool and should be free from burrs. Before Wiring, insert the Power Max EM 6400 into the cutout from the front. Then, fasten the two side clamps from the rear. While supporting the Power Max EM 6400 from the front, tighten both side clamp screws in a criss-cross pattern till all slack is taken up and then apply one full turn. Do not over-tighten.

6. ELECTRICAL INSTALLATION

DANGER M:

All Installation, wiring and periodic maintenance of the Power Max EM 6400 as well as its associated circuits involve high voltages and currents. While this manual suggests several safety and reliability steps, it must be used in conjunction with the safety codes in force at your location. Failure to practice safe working procedures is likely to cause damage to the installation, severe injury and / or death. All work including handling of electrical circuits during Installation, wiring, periodic maintenance must be done only by qualified personnel.

Neither CONZERV nor its agents may be held responsible for damage or death arising out of the wiring and / or PT, CT or other external circuits.

The covers of the Power Max EM 6400 should never be dismantled or opened. There are no user-serviceable parts inside. The Power Max EM 6400 contains high-precision components, which require special handling available only at authorized CONZERV service locations. High voltages are likely to be present inside even after the Power Max EM 6400 has been switched off. Opening the covers of the Power Max EM 6400 and/or any attempts to dismantle, service, repair or modify the unit by unauthorized persons may cause severe injury, will damage the unit and will also render CONZERV's warranty void.

This Chapter describes the following:

- The Need and selection of Potential Transformers (PTs) and Current Transformers (CTs)
- Auxiliary Supply, PT and CT Connections

NOTE: For best wiring results with the new Terminal cover, please ensure the following specs:

Improper wire-man-ship will damage the Terminals and require Factory Replacement. This does not indicate defective manufacture and is not covered by product warranties.

- Power Driver preferred, Hand Screw-Driver OK.
- TIP: Phillips preferred, DO NOT USE POZIDRIV TIPS. Flat OK



Screw Head Diameter = 3.5mm, TIP Shaft Diameter < 5mm.

IMPORTANT - Driver Shafts inserted angularly or of Diameter = 5mm or more WILL GET STUCK in the Safety Cover

Tightening Torque: (25 to 60) N-cm

Loosening Torque: (55 to 60) N-cm

Screw Travel: 6 mm less wire thickness

Torque greater than 60 N-cm may strip the screw or break the Safety Cover.

Worn-out bits and insufficient hold-down pressure while tightening will cause the bit to ride on the screw head thus stripping and damaging it.

6.1. Auxiliary (Control) Power Supply

The Power Max EM 6400 requires a Single-phase ac / dc Auxiliary (Control) Power Supply to supply power to its internal electronic circuitry. The [Setup](#) procedure (Section 3.2) must first be completed, with only the Auxiliary Supply connected.

External surge suppressors are necessary in the Auxiliary Supply Circuit for proper operation during extreme surge conditions, where the voltage surges exceed the Auxiliary Supply limits (E.g. Rural areas and outlying areas prone to lightning strikes).

Auxiliary Supply Range:

- 80 to 270V ac / 100 to 270V dc.
- Burden (load) < 3VA (Auxiliary).

NOTE 1: The Auxiliary Power Supply may be derived from the voltage signals.

NOTE 2: If you have a 440 v Three-Wire Delta system and a reliable Neutral is not available, a 440v: 240v Supply transformer should be used to provide the standard 240v Auxiliary Supply.

DANGER M: Do not feed the Power Max EM 6400's auxiliary power supply terminals with a voltage greater than the rating marked on the label. The Power Max EM 6400 will be permanently damaged and CONZERV's Warranty shall be void.

6.2. PTs and CTs

Large electrical installations have high voltages and currents, which may exceed the direct connection rating of the meter. In this case, Potential Transformers (PTs) and Current Transformers (CTs) are used to precisely “step down” or reduce the voltage and current level to suit the meter rating. Potential Transformers usually have a full-scale output of 110V ac rms line-line and Current Transformers, a full-scale output of 5A or sometimes 1A.

The PTs (Potential Transformers) and CTs (Current Transformers) must be planned, installed and tested by a qualified electrical contractor before wiring the meter. The accuracy of the measurement also depends on the accuracy and phase – angle error of the PTs and CTs. Instrument Class 1 or better PTs and CTs are recommended. Do not use Protection Class (10P10, etc.) CTs to feed the Power Max EM 6400; they have poor accuracy and phase characteristics.

Ensure that the CT Primary rating has been selected so that your normal load variation lies between 40% and 80% of its full scale. If your CT is over-rated, say if the load is always less than 10% of the CT Primary rating, accuracy suffers. On the other hand, if the CT is under-rated, then you may exceed its full-scale and burn out both the CT and the Power Max EM 6400.

6.2.1. PT, CT Wiring

The PTs and CTs must have adequate VA rating to support the burden (loading) on the secondaries. You may want to support the Auxiliary supply burden from one of the PTs. CT wiring can impose additional burden (loading) on the CT. For example, if the CT has a 5A secondary and the wire resistance is 1.0 Ω , then the CT has to support an additional burden of 5VA. If the wiring distance from the CT secondary is greater than stated in Table 6.1, then the CT could get over-burdened and give large errors. Choosing a 1A CT secondary can reduce this error. The CT Secondary value must be user programmed into the meter.

The Power Max EM 6400 should be conveniently located for easy connections of voltage (PT) and Current (CT) signals, the auxiliary (control) supply.

NOTE 1: The Power Max EM 6400's Field Programmable PT and CT Primary or secondary Settings may be utilized to Calibrate out the PT and CT amplitude error, for improved accuracy.

6.3. Voltage Signal Connections

For proper meter operation, the voltage connection must be maintained. The voltage must correspond to the correct terminal. The cable required to terminate the voltage sense circuit should have an insulation rating greater than 600V ac and a current rating greater than 0.1A.

There are 4 Voltage input terminals marked V1, V2, V3 and Vn. See the wiring diagrams that follow, for details. **For Delta connection, the Vn terminal should be left un-connected.**

6.3.1. PT Connections

The EM 6000 directly accepts LT voltage inputs of up to 500 V ac rms Line to Line. Voltages greater than this, typically HT systems, must be connected through Potential Transformers (PTs). The Power Max EM 6400 allows Field Programming of both PT Primary and Secondary voltages. See the voltage input overload graph for more detail

Field Programmable PT Primary range : 0.1 to 999 kV ac rms L-L.
 Field Programmable PT Secondary range : 100 to 500v ac rms L-L.
 Power Max EM 6400 Voltage Input burden : 0.2 VA per input.

See Section 3.2 ([Setup \(Field Programming\) section](#)) for programming details.

IMPORTANT: The PT Primary and Secondary values must be User Programmed before using the Meter. Otherwise, the readings will be wrong.

CAUTION . . . : Before wiring, de-energize the PT secondary by opening the circuit or removing the fuse. Do not short the PT secondary.

6.3.2. Selecting the Voltage Fuses

We strongly recommend using fuses on each of the sense voltages and the control / auxiliary power, although connection diagrams often do not show them. Use a 1A fuse on each voltage input.

6.4. Current Signal Connections

The meter accepts up to 6A ac rms per channel directly. Above that, a Current Transformer must be interposed to scale down the current.

There are three pairs of Current Input terminals marked A1, A2 and A3. Each pair of input terminal is labelled as (S1, S2) and has an arrow indicating the direction of current flow. For proper measurements, the phase identification as well as the polarity of the current signals must be correct. The Forward flow (Import by consumer) current direction must be into the S1 terminal and the exit from the S2 terminal. Please maintain the correct sequence and polarity to avoid wrong readings.

Any unused current input terminals (e.g. A2 (S1, S2) for Delta) must be shorted together. The shorted terminals do not need to be grounded.

Install the wiring for the current circuit at 500V ac insulation as a minimum. The cable connection should be rated for 7.5A or greater and have a cross-sectional area of 16AWG minimum.

CAUTION . . . : Before wiring, de-energize the CT secondary by shorting it via a shorting block.

Under no circumstances must the CT secondary be left open-circuited, even momentarily, when primary current is flowing. This causes high voltages that will overheat and explode the secondary of the CT and damage the instruments as well.

6.4.1. CT Connections

Mount the current transformers (CTs) as close as possible to the meter for best accuracy. The following table illustrates the maximum recommended distances for various CT sizes, assuming the connection is via 16AWG cable.

Table 6.1: CT Size and Maximum Distance

5A CT Size	Maximum Distance (CT to Meter)
2.5 VA	10 Feet
5.0 VA	15 Feet
7.5 VA	30 Feet
10.0 VA	40 Feet
15.0 VA	60 Feet
30.0 VA	120 Feet

Field Programmable CT Primary range : (1A to 999kA) ac.
 CT Secondary : (1A or 5A) ac (programmable)
 Other values are also programmable to compensate CT errors if desired.
 EM 6000 CT burden : 0.2VA maximum per input.
 See the [Setup \(Field Programming\) section](#) for programming details.

IMPORTANT: The CT Primary and Secondary values must be User Programmed before using the Meter. Otherwise, the readings will be wrong.

NOTE 1: With Dual - Range CTs, select the best range for programming the Power Max EM 6400. Do not change the range thereafter without re-programming the Power Max EM 6400; the Power Max EM 6400 will read erroneous values.

6.4.2. CT Polarity

When the meter is connected using the CTs, you must maintain the correct CT polarities. CT polarities are dependent upon correct connections of CT leads, and upon the direction the CTs are facing when clamped around conductors. The dot on the CT must face the line side; the corresponding secondary connection must connect to the appropriate input on the meter.

Failure to connect CTs properly results in inaccurate power readings. If your meter is not reading power properly, it is more than likely that the CT is incorrectly wired. If one or two CTs are reversed, then Energy parameters accumulate only one phase value. If two or all the phases of the CT are reversed, Energy will not accumulate. (Energy Export will not be measured).

6.4.3. CT Connection Reversal

To check the polarity of the CT after the meter has been installed, simply look at the phase-wise W (Watt) readings to see that each of the readings are positive (assuming you are consuming power). If one of the W readings is negative, that particular phase CT is reversed and must be corrected. On the other hand if you are exporting power, all three phase-wise W readings must be negative.

6.5. Setup – System Type

The Power Max EM 6400 needs to know what type of 3-phase system it is connected to. This is programmed in the [Setup procedure](#) (Section 3.2), before using the meter. The meter does allow you to change this setting while it is running; however, this capability is meant for correcting a gross error, or for training or educational purposes, not to be changed regularly. The options are:

- Star (Wye). For 3 phase, 4 wire, “Three Watt-meter” or “Three Element” circuits. Here, all three voltage Phase signals, the Neutral voltage connection and all three current input signals need to be wired in, means all the 4 voltage terminals and 6 current terminals described in the following section, need to be wired.
This setting is also used for Single Phase Circuits. Here, the V1 and VN terminals as well as the A1 (S1 and S2) terminals will be used to sense a single voltage and a single current.
- Delta. For Three Phase, Three Wire, “Two Watt-meter” or “Two Element” circuits.

6.6. Phase Labels

The Phase Labels shown on the display are programmable via the Power Max EM 6400 Front Panel Set up menu. The choices available are: 123 (factory set), ryb, rSt, Pqr, Abc.

6.7. Connection Diagrams

Choose the diagram below that best describes your application. You must ensure that the CT phase and corresponding PT phase are identical and that the CT polarity is correct as explained in “[CT Polarity](#)” above. Follow the outlined procedure to verify correct connection.

6.7.1. Power Max EM 6400 Rear Panel

The meter terminals are located on the rear panel. 14 terminals are provided, 7 terminals on each side:

- Six terminals for current, one “in” and one “out” per phase,
- Four terminals for voltage, for three phases and neutral
- Two terminals for meter Auxiliary Power Supply and
- Two terminals for the RS 485 communications port.

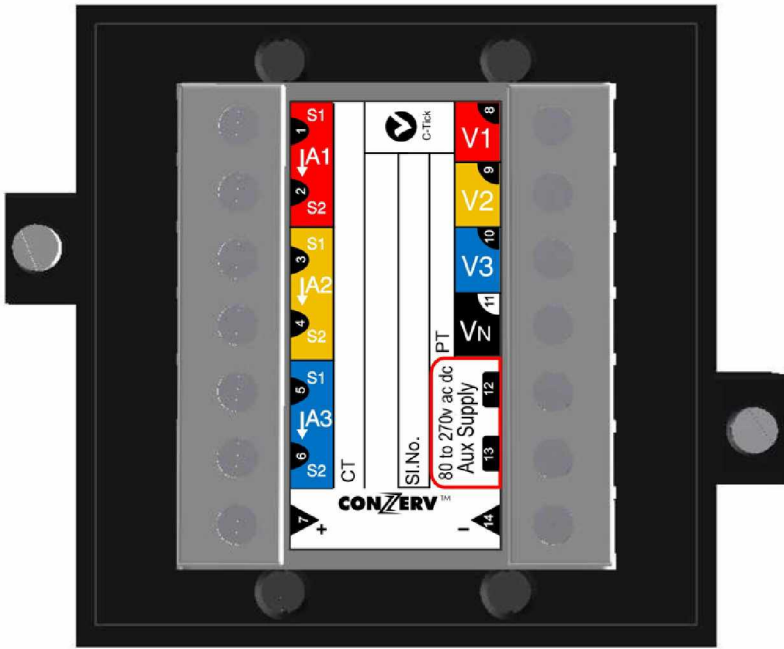

Figure 6.1: Meter Rear panel

6.7.2. Three Phase 3 Wire Delta

With 2 CTs. Direct Voltage Connections if Voltages are less than 601V ac L-L. Otherwise, 3 PTs for Closed Delta or 2 PTs for Open Delta.

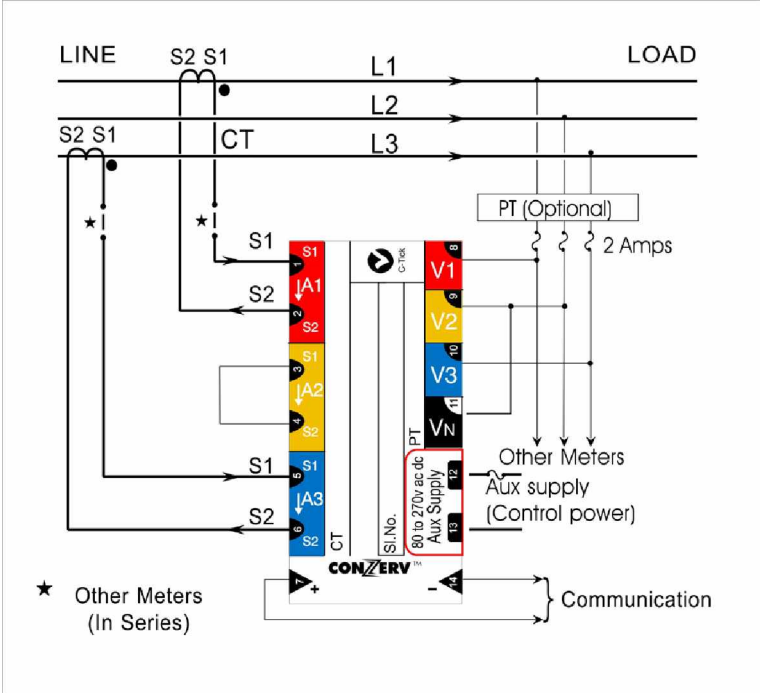

Figure 6.2: The Delta Connection Diagram

Note: Remember to make sure Delta is programmed in the meter Setup. Leave the Vn terminal un-connected.

6.7.3. Three Phase 4 Wire Star (Wye)

3 CTs. Direct Voltage Connections if Voltages are less than 601V ac L-L. Otherwise 3 PTs. For Single Phase, the same diagram is used except that only Phase 1 connections exist and Phase 2 and Phase 3 are unused. The unused current terminals must be shorted together to reduce noise picked up in the meter.

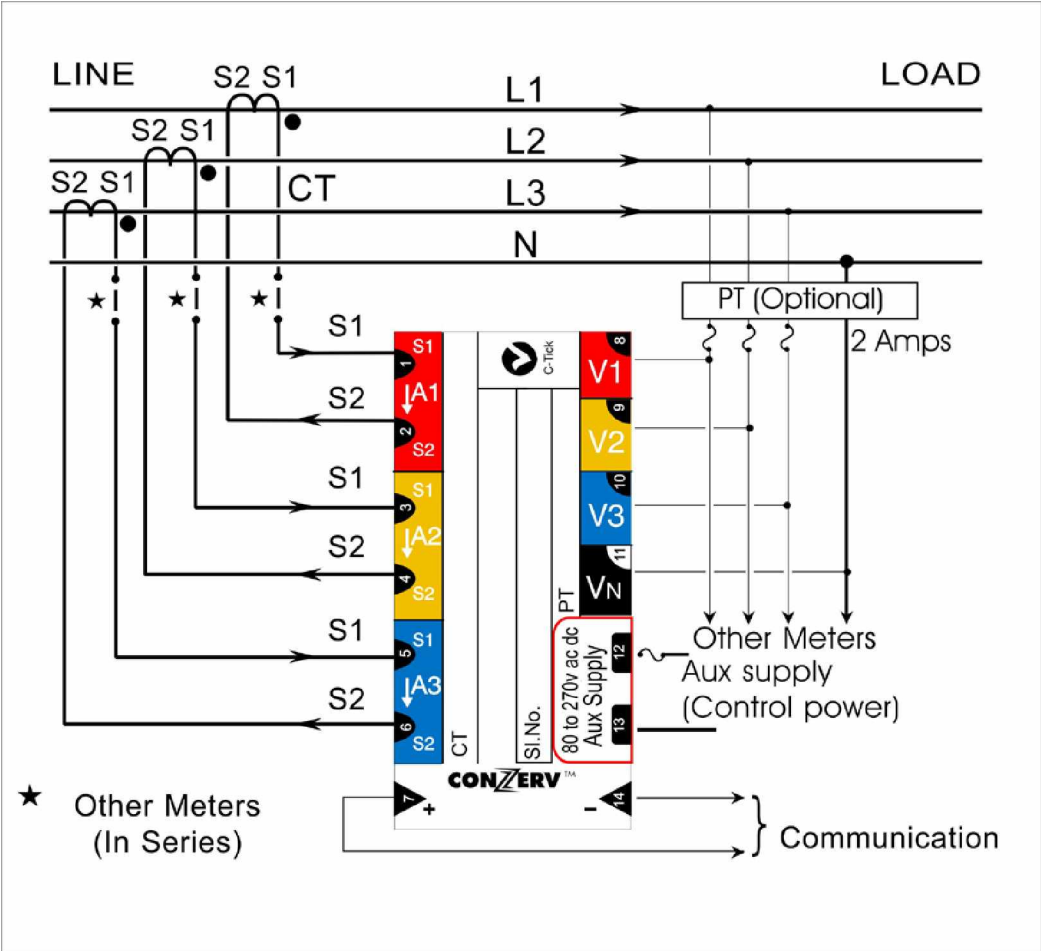

Figure 6.3: The Star (Wye) 3phase 4wire Mode Connection

7. COMMUNICATION INSTALLATION

7.1. RS-485

Each Power Max EM 6400 series instruments have a unique address up to three digits long. The range of the instrument address is 1 to 247. This allows the user to communicate with up to 247 instruments on one COM port of the PC. The Power Max EM 6400 series works on the Modbus RTU protocol. Under Modbus, each port supports up to 247 instruments. However, each RS485 segment allows only 32 nodes (instruments). Therefore, Data Repeaters are necessary to amplify the signal between segments.

Available standard baud rates are 1200, 2400, 4800, 9600 and 19200. To select the proper baud rate, apply the following rules:

- For best results under normal conditions, leave the meter factory-set at 9600 baud.
- For a smaller number of instruments over a long distance, use a low baud rate 4800 / 2400 / 1200.
- In noisy EMI, RFI conditions, try 4800 or 2400 baud.
- With short cable runs (< 300 meters or 975 feet), 19200 baud speeds up data transfers.

The connection diagrams show one Termination Resistor (RT) across the cable-pair at each end of the cable. This is a 1W resistor, 5% or better. Its value should approximately equal the Impedance of the Data Cable, as specified by the cable manufacturer. If you're not sure, a value of 120Ω might just work fine.

The termination resistors help absorb the data signal reflections off the ends of the cable, reducing data packet defects and the corresponding data packet re-transmissions. In cable runs longer than say 200 meters (650 feet), and with baud rates higher than 9600 baud, these benefits become more apparent.

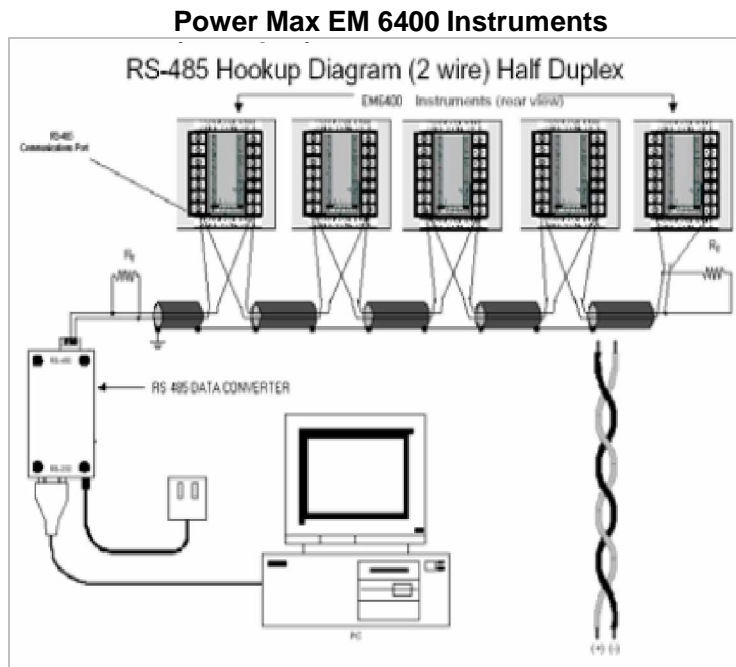

Figure 7.1: 2 Wire Half Duplex Communication Connection

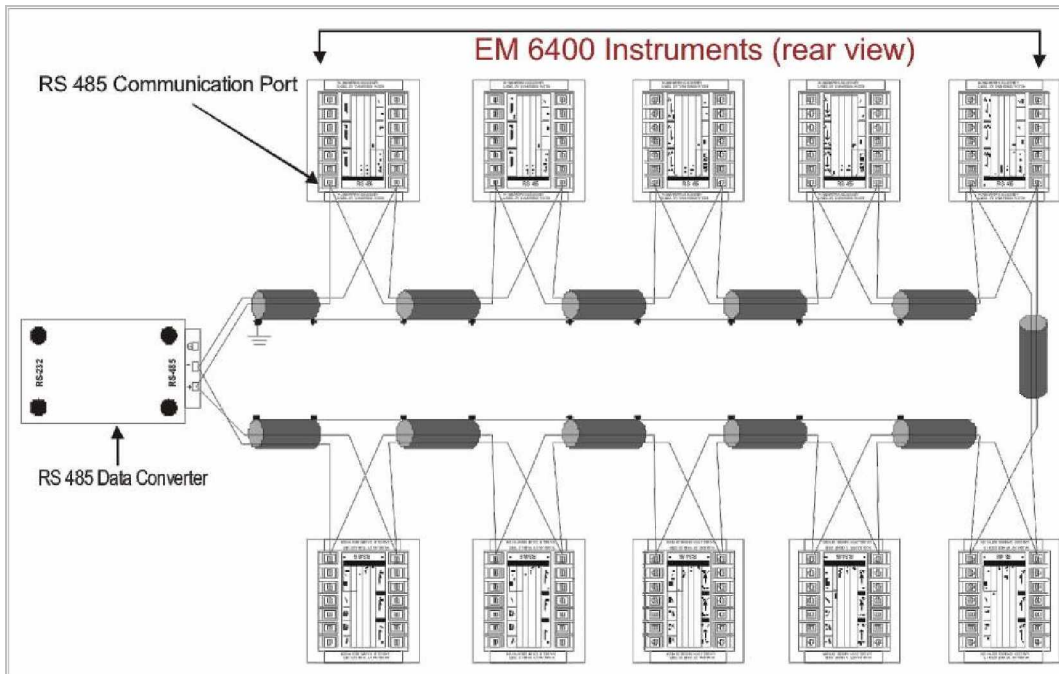

Figure 7.2: Closed Loop, 2 Wire Half Duplex

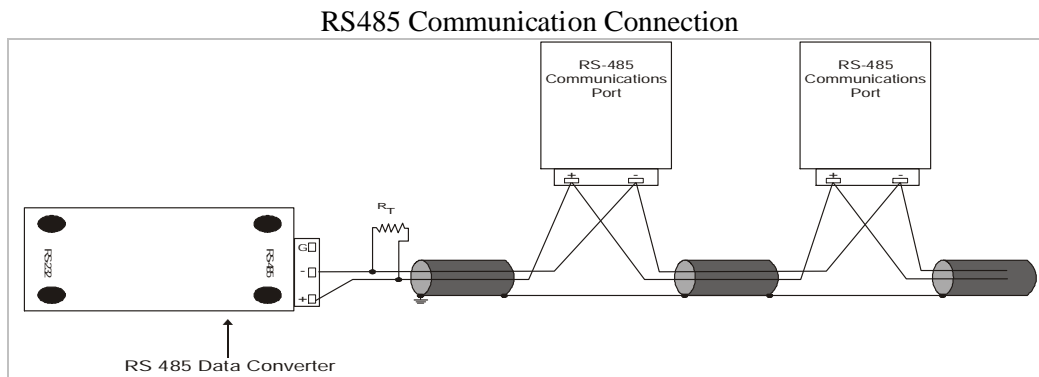

Figure 7.3: Detail of Closed Loop, 2 Wire Half Duplex

7.2. Repeaters

RS-485 Transceivers (Repeaters) of the Half-Duplex variety are required for large networks of instruments.

- In a two-wire connection, a maximum of 247 instruments on one COM port of the PC can be included in the same network.
- One RS 485 Segment can accommodate only 32 Devices.

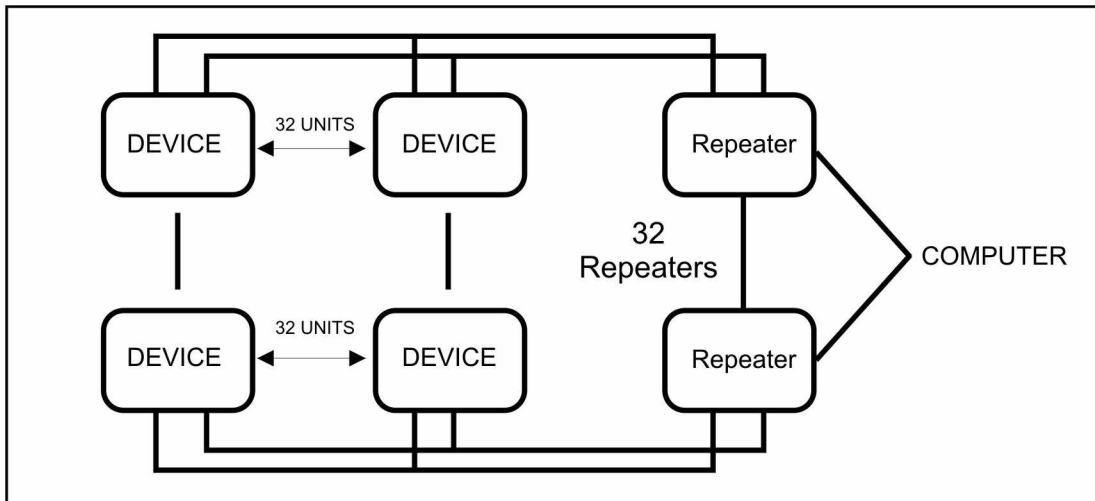

Fig.7.4: Two-Wire RS-485 Communication Installation Connection with Repeaters

7.3. Factory Settings

- Communication Protocol: Modbus – RTU
 - Baud Rate: 9600 bps
 - Data bits: 8
 - Stop bits: 1
 - Parity: Even
- Data type: 32-bit Float (Real) for all parameters unless otherwise specified.
 - Except for parameter:
 - § Intr (Number of interruptions (Outages) in RmS parameter blocks) – unsigned 32-bit integer data type.
 - § RunSec (Run Seconds in Integrated block) – unsigned 32-bit integer data type.
- Data Format: Direct reading from the meter, no scaling is required.
- Modbus Function code: 03 (Read)

7.4. Modbus Registers

- Before integrating the Meters into your SCADA network, your SCADA software must be configured for Modbus RTU communication, for the Address Blocks below, **by a qualified technician who understands your SCADA software**. Typically, the Device Address, Block Start Address, Number of Registers (20 registers per Power Max EM 6400 Data block of 10 x 32 bit values), must be configured to suit the meter. Additionally, related SCADA settings for polling priority, logging and viewing the Data must also be made. Refer your SCADA software instructions on how to do this.
- Serial data from the Meter is available via the Modbus RTU protocol on the Serial RS485 port. The Unit ID, which is unique to each meter, is programmed via the “Set-Up” Menu through the Front Panel keys.
- All addresses are in Decimal. However, check your SCADA Programme’s Modbus driver specs such as an offset of 40,001. In this case of Power Max EM 6400, Address 3000 must be treated as Modbus Register Address 43,001.
- The Power Max EM 6400 supports the transfer of whole block and also of individual Data values (2 Registers are used for storing single Data value)
 - In transfer of whole block, it basically treats each block as an object with the starting address (e.g. 3000) considered as the object name. This enables fast block-transfers, since

Energy Management usually requires a block of related readings as of the same point of time. This method also eliminates time-skew within readings of that Block.

- In transfer of individual data values, it basically treats 2 registers as an object with the starting address (e.g. 3900) considered as the object name. This enables to transfer required data values for energy management.
- Most of the data are in 32bit format (IEEE Single Precision Float). 2 registers are used for storing a single data value. A float (or real) setting on your SCADA Driver will usually suffice for automatic conversion. A few values are in Unsigned Long (32 bits).
- Your SCADA software must support Register Blocks consisting of different Data Types (Integers and Floats) to transfer of Whole Block.
- Each Modbus register size is 16-bits. All Power Max EM 6400 readings are 32 bits. Therefore, each Power Max EM 6400 reading occupies TWO consecutive Modbus Registers.
- Most advanced SCADA packages will provide these capabilities.

1.1.2. Phase Labels

**Table 7.1: Phase Labels (Programmable through Setup)
Factory Default = 1 2 3**

1	2	3
R	Y	B
R	S	T
P	Q	R
A	B	C

7.4.1. Parameters not available on Display

Voltage phase angle parameters are not available on the Front Panel Display but available on the RS485 communication port:

S.No.	Parameters not available on Front Panel Display
1.	Voltage Phase Angle Phase – 1
2.	Voltage Phase Angle phase – 2
3.	Voltage Phase Angle Phase – 3

END OF DOCUMENT