

SPLIT CORE CURRENT
 TRANSFORMER
MODEL 9SP

2.88" x 7.75"

PAGE No 3-12

REV 19DEC00

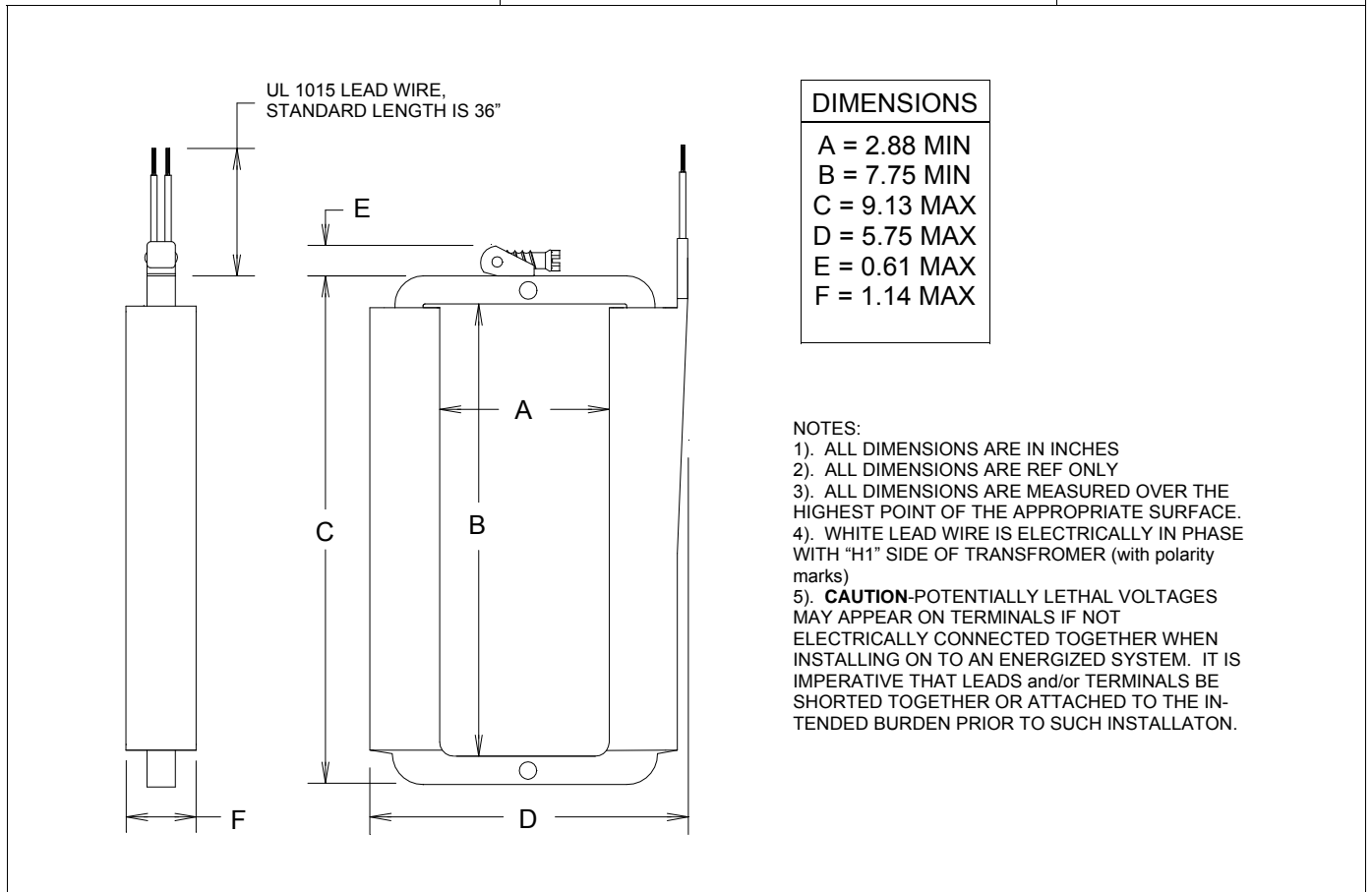

Specifications

- Secondary sources 5 amps AC at rated F.S. primary current
- Nominal operating frequency range is 50-400HZ
- Thermal rating factor is 1.33 @ 30C for ratios up thru 7500:5A, 1.15 @ 30C for ratios of 7500:5A and above
- Insulation voltage class is 0.6KV BIL 10KV
- For indoor applications only
- Reference documents C57.13, UL 1244, CSA CAN3-C13-M83, and IEC 44-1
- CT can be split apart and reassembled onto the primary conductor without interrupting service. **NOTE: Safety precautions must be observed**
- CT is finished in heavy vinyl tape with dipped acrylic overcoat. Uses imbedded SS band to secure two halves of transformer together

Options, contact Factory for information

- UV resistant Nylon band to secure two halves of transformer together (9SPS model)
- Reversed polarity, BLK lead wire is made X1
- 1, 0.2, and 0.1 A output at F.S. primary amperage. Other non-standard ratings also available
- 8-32 screw terminals
- Custom lead wire lengths and types
- Thermal ratings above 1.33 for selected ratios

SPLIT CORE CURRENT
TRANSFORMER
MODEL 9SP

K-Tech Inc.
www.K-tech.com
meters@K-Tech.com
1 224-356-9865

TYPICAL EXCITATION CURVE for WICC MODEL 9SP at 60HZ

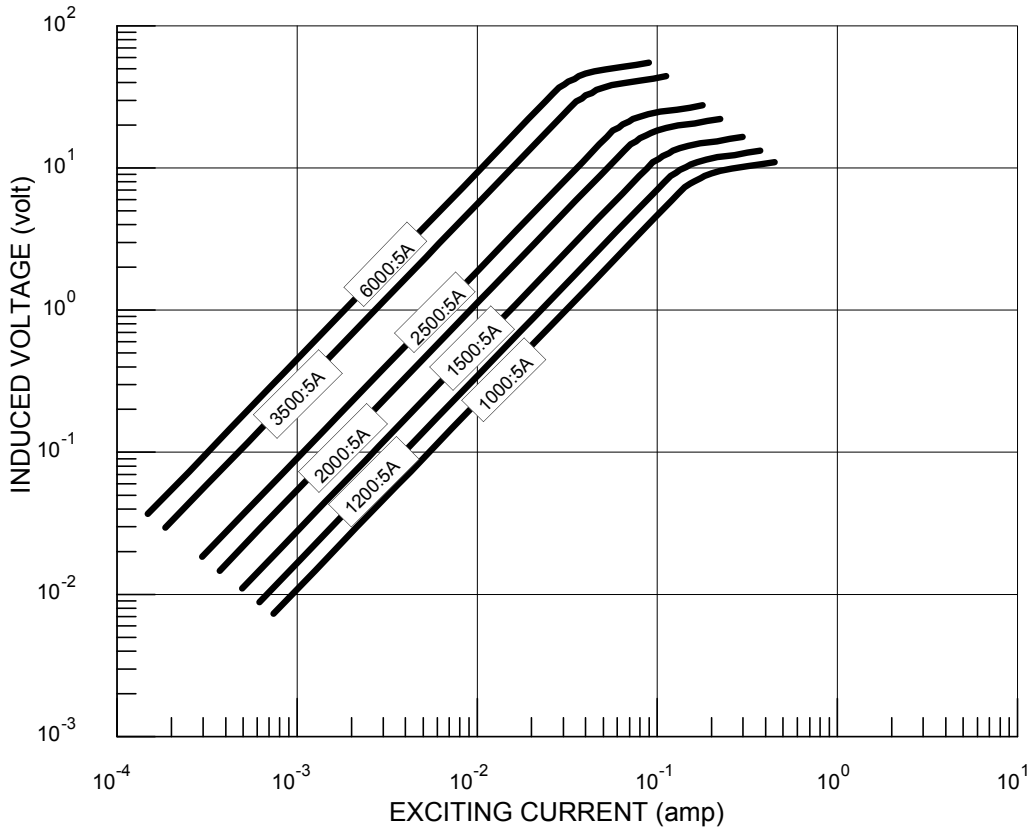

W.I.C.C. PART NUMBER *	RATIO	ACCURACY @ 60HZ		NOMINAL WINDING RESISTANCE (ohm)	LEAD WIRE SIZE (AWG)
		± %	BURDEN (VA)		
9SP-1000-00-xxx	1000:5A	1.0	5.0	0.34	16
9SP-1200-00-xxx	1200:5A	1.0	10	0.40	16
9SP-1500-00-xxx	1500:5A	1.0	15	0.50	16
9SP-2000-00-xxx	2000:5A	1.0	40	0.54	16
9SP-2500-00-xxx	2500:5A	1.0	50	0.84	16
9SP-3500-00-xxx	3500:5A	1.0	50	1.18	16
9SP-6000-00-xxx	6000:5A	1.0	50	1.70	16

* "xxx" describes termination: "T" FOR SCREW TERMINALS, "Lyyy" FOR LEAD WIRES (Where "yyy" is the lead length in inches. For example, "L24" represents 24 inch long lead wires.)

NOTE ON ACCURACY: Because of the inherent design of this type of current transformer, accuracy is defined, in part, by the care with which the user installs the device. It is imperative that absolute cleanliness of the core mating surfaces be maintained during installation. Accuracy listed is verified at time of shipment and, with proper installation, should be realizable in the field.