

DIN Integra 500 Series

Integra 500 digital meters replace numerous single-function instruments, providing the ideal solution for new or retrofit projects by bringing significant cost savings and reduced wiring times. The range offers a combined ammeter, voltmeter and frequency meter alongside a combined maximum demand ammeter and voltmeter. Models 530 and 540 have been enhanced with one or two additional set-point relays added to the base combined maximum demand ammeter and voltmeter unit.

Up to 15 electrical and power measurement parameters and programmable current transformer ratios can be displayed on the Integra 500's front panel. The parameters can be modified on the menu-driven interface and viewed by scrolling through up to 5 screens on the high contrast LCD display. The solid state technology is ideal for Genset and other high vibration environments.



Operation

Model 510 - Three-Phase Ammeter, Voltmeter and Frequency Meter

Ideally suited for Genset, feeder panel and low-voltage switchgear applications, this integrated unit typically replaces three conventional ammeters, a voltmeter, a selector switch and a frequency meter. Integra 510 offers programmable current transformer ratios up to 8000A, and the configuration and display of up to 12 electrical parameters. Status information is displayed on 3 screens for current per phase and system average, voltage per phase and system average, and system frequency.

Model 520 - Three-Phase Maximum Demand Indicator, Ammeter and Voltmeter

Within one compact unit, the Integra 520 provides all the functionality typically associated with three separate maximum demand indicators and a voltmeter. The unit provides simple configuration, measurement and monitoring of up to 15 electrical parameters as viewed through 5 screens. Integra 520 offers programmable current transformer ratios up to 8000A, and programmable demand integration time periods with maximum demand reset.

Model 530 - Three-Phase Maximum Demand Indicator, Ammeter and Voltmeter with Maximum Demand Set-Point Relay Output

Integra 530 offers all the benefits of model 520 with an additional programmable set-point trip relay output. When the demand current exceeds the desired set-point limit the relay will energise. The relay can be used as an alarm, or as part of an automatic load shedding system to help prevent higher utility tariffs being imposed. The relay will automatically reset once demand current falls below the set-point value.

Model 540 - Three-Phase Maximum Demand Indicator, Ammeter and Voltmeter with Two Maximum Demand Set-Point Relay Outputs

Integra 540 offers all the benefits of model 530 plus two programmable set-point trip relay outputs. The incorporation of two output relays allows for early warning alarms, or applications such as selective two-stage load shedding to help prevent higher utility tariffs being imposed. The relay will automatically reset once the demand current falls below the set-point value.

Maximum Demand

Most electricity utilities base their charges on power consumption, historically using a thermal maximum demand indicator (MDI) to measure peak power consumption averaged over a number of minutes, thus avoiding artificially high readings caused by surges. The Integra 500 series utilises a sliding window algorithm to simulate the characteristics of a thermal MDI, but updates the reading every 1/8th of a demand period for highly accurate measurements. The demand period is re-initialised at power up, and when system power or demand integration times are altered.

System Input

Designed for all low-voltage switchgear and distribution systems, the Integra 500 series offers programmable CT ratio capability. Direct connected up to 480V ac with 5A CT inputs as standard, with a 1A CT input available as an option.

Features

- Measurement and display of up to 15 electrical parameters
- High contrast LCD display
- Relay trip point models
- Fully programmable CT ratios
- Industry standard DIN96 case style
- 3-phase 3- or 4-wire options
- Wide operating temperature range
- Vibration resistant solid state technology

Benefits

- Replaces multiple single function instruments
- Simple menu driven interface
- Significant cost savings
- Reduced wiring times
- 1.5% accuracy
- Measures down to 2.5% of nominal input
- Monitoring, control and protection of expensive power assets

Applications

- Switchgear
- Distribution systems
- Generator sets
- Control panels
- Embedded generation
- Utility power monitoring
- Process control
- Motor monitoring
- Feeder panels
- Distribution pillars

Compliant With

- UL3111-1
- IEC1010-1/BSEN 61010-1 CAT III
- IEC688:1992/BSEN 60688

Measurement and Display

Integra 510

Up to 9 electrical parameters can be displayed via 3 screens

- 1 Current L1
Current L2
Current L3
- 2 Volts L1–N (4-wire only)
Volts L2–N (4-wire only)
Volts L3–N (4-wire only)
- 3 Volts L1–L2 (3-wire only)
Volts L2–L3 (3-wire only)
Volts L3–L1 (3-wire only)
- 4 System volts
System current
System frequency

Integra 520, 530 and 540

Enhanced status information of up to 15 measured parameters can be displayed via 5 screens

- 1 Current L1
Current L2
Current L3
- 2 Current demand L1
Current demand L2
Current demand L3
- 3 Current maximum demand L1
Current maximum demand L2
Current maximum demand L3
- 4 Volts L1–N (4-wire only)
Volts L2–N (4-wire only)
Volts L3–N (4-wire only)
- 5 Volts L1–L2
Volts L2–L3
Volts L3–L1

Programmable Display

A two-button interface on the front panel of Integra 500 provides simple programming of device settings and adjustment of operating parameters. Once configured, measurements can be viewed by scrolling through up to 5 screens featuring a high contrast 3-line, 4-digit LCD display, with annunciators for each screen. Models 530 and 540 offer optional set-point relay outputs, providing maximum demand alarms. To prevent unauthorised access to the configuration settings and re-settable maximum demand registers, screens offer password protection.

Programmable Parameters

Parameter	Range
Password:	4-digit 0000-9999
Primary current:	Max 8000:5A
Demand integration time:	8, 15, 20, 30 minutes
Reset:	Maximum demand

Product Codes

Product code	Product configuration
244-513W.*.**	Integra 510 3-phase 3-wire
244-514W.*.**	Integra 510 3-phase 4-wire
244-523W.*.**	Integra 520 3-phase 3-wire
244-524W.*.**	Integra 520 3-phase 4-wire
244-533W.*.**	Integra 530 3-phase 3-wire, one set-point relay
244-534W.*.**	Integra 530 3-phase 4-wire, one set-point relay
244-543W.*.**	Integra 540 3-phase 3-wire, two set-point relays
244-544W.*.**	Integra 540 3-phase 4-wire, two set-point relays
Input range*	
10LA	100-120V L-L (58-69V L-N), 1A CT input
19LA	190-240V L-L (110-139V L-N), 1A CT input
38LA	380-480V L-L (219-277V L-N), 1A CT input
10LS	100-120V L-L (58-69V L-N), 5A CT input
19LS	190-240V L-L (110-139V L-N), 5A CT input
38LS	380-480V L-L (219-277V L-N), 5A CT input
Auxiliary supply suffix **	
Self powered	SP
10	100-120V ac
19	190-240V ac
38	380-480V ac

Order Code Example

244-513W-10LS-10 - Integra 510 digital metering system, 3-phase 3-wire, 100-120V L-L, 5A CT input, auxiliary supply 100-120V ac

Specifications

Input	
Nominal input voltage:	100-120V L-L (58-69V L-N) 190-240V L-L (110-139V L-N) 380-480V L-L (219-277V L-N)
Max continuous input voltage:	120% nominal
Max short duration input voltage:	2 x for 1 sec., repeated 10 times at 10 sec. intervals
Nominal input voltage burden:	0.2 VA approx per line
Nominal input current:	1 or 5A ac (rms)
System CT primary values:	0 to 99.99A:1 to 80A, 0 to 999.9A:81 to 800A or 0-9999A:801 to 8000A
Max continuous input current:	120% nominal
Max short duration current input:	20 x for 1 sec., repeated 5 times at 5 min. intervals 10 x for 3 sec., repeated 5 times at 5 min. intervals 5 x for 5 sec., repeated 5 times at 5 min. intervals
Nominal input current burden:	0.6 VA approx per phase
Relay outputs (530 & 540 only)	
Configuration:	Model 530: 1 x single pole change over Model 540: 2 x single pole change over
Rated current:	8A
Rated voltage:	250V ac
Max breaking voltage:	440V ac
Rated breaking capacity:	2000VA
Contact life:	>30,000 operations
Auxiliary	
Standard nominal supply voltage:	100-120, 190-240 or 380-480V ac
Auxiliary volts tolerance:	Nominal -10% to +20%
AC supply frequency range:	45-66Hz
AC supply burden:	Models 510 and 520: 3VA Models 530 and 540: 6VA
Measuring ranges	
Voltage (self powered):	75-125% of nominal
Voltage (auxiliary powered):	2.5-120% of nominal
Line-to-line voltage 4-wire:	0-10% difference in phase voltage
Current:	2.5-120% of nominal
Current demand:	2.5-120% of nominal (Model 510: not applicable)
Reference conditions	
Ambient temperature:	23°C
Input frequency:	45-66Hz
Input waveform:	Sinusoidal (distortion factor <0.005)
AC auxiliary supply waveform:	Sinusoidal (distortion factor <0.05)
Magnetic field of origin:	Terrestrial flux
Accuracy	
Voltage:	1.5% of nominal
Current:	1.5% of nominal
Current demand:	3% of nominal (Model 510: not applicable)
Frequency:	0.5% of mid frequency
Temperature coefficient:	0.013%/°C typical
Display update time:	Current & volts: 7.5 seconds approx Current demand & max current demand: 1/8th of demand period (Model 510: not applicable)
Circuitry response time:	<10 seconds to step input
Enclosure	
Enclosure style:	DIN 96 panel mount
Display:	3-line 4-digit LCD. 10.5mm high characters
Compliant with:	UL3111-1, IEC 1010-1/BSEN 61010-1 CAT III, IEC688:1992/BSEN 60688, EMC and LVD
Material:	Polycarbonate UL94V-0/V-2
Terminals:	M3.5 captive screw-clamp
Fixing:	2 corner clamps and thumb screws
Dielectric voltage withstand:	300-600V: 3.25kV rms 50Hz for 1 minute 150-300V: 2.2kV rms 50Hz for 1 minute
Operating temperature:	-10 to +70°C
Storage temperature:	-20 to +80°C
Relative humidity:	0-95% non condensing
Warm-up time:	1 minute
Shock:	30g in 3 planes
Vibration:	10-15Hz, 1.5mm peak to peak / 15-150Hz @1g
Front of panel IP protection:	IP54
Dimensions:	96mm wide x 96mm high x 112mm deep wide 3.78" wide x 3.78" high x 4.41" deep
Panel cut-out:	92mm x 92mm, 3.62" x 3.62"



Integra 540



Integra 510



Integra 540



Integra 510

Dimensions

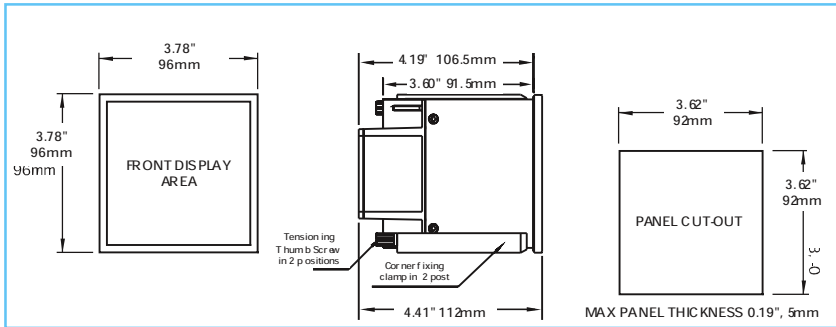

Connections

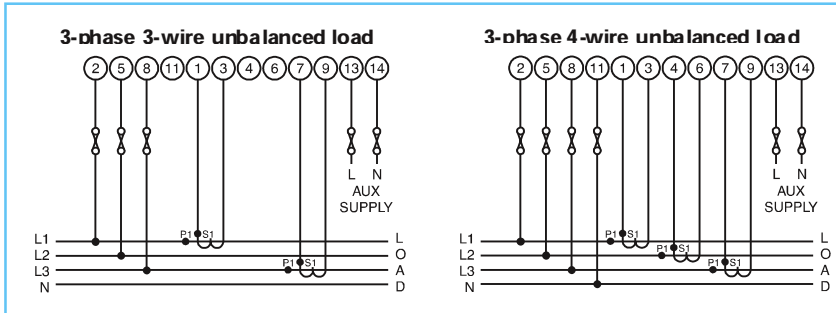

Relay Connections

Models 530 and 540

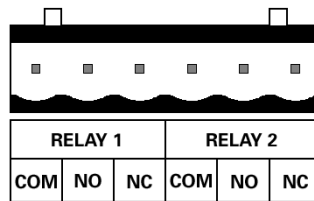

Rear view.

Integra 530 has only relay 1. Integra 540 is fitted with relay 1 and relay 2.

Wiring

Input connections are made directly to shrouded screw-damp terminals. Terminals for both current and voltage connections are sized to accept two #12 AWG (3mm²) solid or stranded wires. Connections for relay options are via screw-clamp connectors. Connectors offer retained wire protection leaves suitable for one #13 AWG (2.5mm²) solid or stranded wire.

Auxiliary Supply

The Integra 500 should ideally be powered from a dedicated supply. However the device may be powered from the signal source, provided this remains within the working range of the chosen auxiliary supply.

Fusing

It is recommended that all voltage lines are fitted with 1 amp fuses.

Safety / Ground Connections

For safety reasons, CT secondary connections should be grounded in accordance with local regulations.