

DU-35RTD

100ΩPt RTD Temperature Meter
3 1/2 Digit with 0.56" LEDs
in a 1/8 DIN Case

Economical, 3 Wire or 4 Wire 100Ω Platinum RTD Temperature Meter.

General Features

The DU-35RTD is a versatile and economical temperature meter, designed to accept 3 wire or 4 wire 100Ω Platinum RTD sensors. The meter is ordered factory calibrated for either a °C or °F read-out, and a 0.1° or a 1° resolution and is shipped in the 3 wire mode. The 4 wire mode may be header selected by the user. If required in the future, the user can re-calibrate the meter on-site without any component changes by following the instructions on page 2 of this data sheet and utilizing the internal °C or °F and 0.1° or 1° header. A special option P/N: DU-C/F can be ordered that provides a header on the display front to select between °C or °F without the need for re-calibration. (See Ordering Information)

Typical Application Connections

Temperature Measurement with 3 Wire RTD

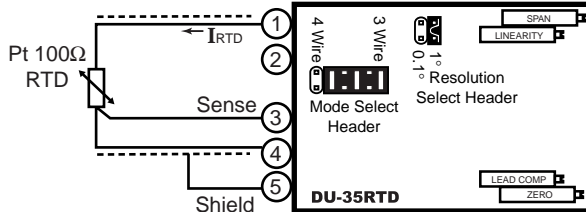

Temperature Measurement with 4 Wire RTD

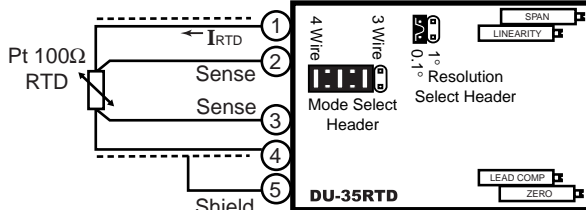

Temperature Measurement with 2 Wire RTD

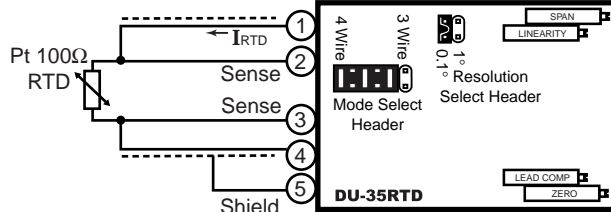

Sense input leads should be joined to the I_{RTD} leads as close as possible to the sensor element because, on 2 wire RTDs, the single lead length resistance from the sensor to these joints will produce uncompensatable errors.

Compatibility

The DU-Series have a matching DIN case style that is complementary to the Lynx, Leopard and Tiger family of meters. DU-Meters are the OEM's choice for economical switchboard and process indication. For economy, each model is dedicated to a specific application and designed for quick and easy installation.



Specifications

Input Configuration:3-Wire or 4-Wire (0.00385Ω/Ω/°C)
Input Ranges:-190.0°C to +199.9°C (0.1°C resolution)
.....-190°C to +800°C (1°C resolution)
.....-199.9°F to +199.9°F (0.1°F resolution)
.....-199°F to +1470°F (1°F resolution)

Lead Imbalance Error:2.8°C per ohm of imbalance
Lead Resistance:Up to 50Ω of resistance in each lead can be automatically compensated

Input Protection:25V AC/DC
A/D Converter:12 Bit Dual Slope
Accuracy:±(0.3% + 1 digit)
Temperature Coefficient: 100ppm/°C (Typical)
Warm Up Time:One minute to specified accuracy
Conversion Rate:3 readings per second
Display:0.56" hi efficiency Red or optional Green LEDs. Display Hold & Display Test are provided.

Polarity:Bipolar. Assumed positive, displays negative
Decimal Selection:Header under face plate, X•X•X•X•
Over-range:Most significant "1" digit is displayed with all other digits blanked

Power Supply (std):120/240V AC, 50/60 Hz. approx 2.5W.
(Optn) VO-DC/ISOIsolated Swtr. 9 to 36V DC/12 to 24V AC
(Optn) VO-24VIsolated Transformer 24V AC ±10%
(Optn) VO-5V DCNon-isolated 5V DC ±10%

Operating Temperature:-10 to 50 °C
Storage Temperature:-20 to 70 °C
Relative Humidity:95% (non-condensing)
Case Dimensions:1/8 DIN, Bezel: 96x48mm (3.78"x1.89")
Depth behind bezel 117 mm (4.61") plus 11.8mm (0.47") for Right-angled Connector or 20mm (0.79") for Straight-through Connectors.

Weight:11 oz., 14 oz when packed

DU-Series, the OEMs choice for switchboard and process indication

DU-35AC11/5AC amps, Scaled RMS. (1 or 5 Amp Internal shunt), 3.5 digit
DU-35ACIRMS1/5 ..AC amps, True RMS. (1 or 5 Amp Internal shunt), 3.5 digit
DU-40AC11-5AC amps, Scaled RMS. (1 or 5 Amp Internal shunt), 4 digit
DU-35ACAC volts, Scaled RMS. 199.9/700V AC Header Selectable Ranges, 3.5 digit
DU-35ACRMSAC volts, True RMS 199.9/700V AC Header Selectable Ranges, 3.5 digit
DU-40ACAC volts, Scaled RMS. 700.0V AC full scale, 4 digit
DU-35HZ15.0Hz to 199.9Hz or 15/500Hz. Up to 700V AC input, 3.5 digit
DU-35DC volts ±2V/±20V/±200V Header Selectable Ranges, 3.5 digit
DU-35MVDC mV ±50mV, ±100mV, ±200mV Header Selectable Ranges, 3.5 digit

DU-45DC volts ±2V/±20V/±200V Header Selectable Ranges, 4.5 digit
DU-45MVDC mV ±50mV/±100mV/±200mV Header Selectable Ranges, 4.5 digit
DU-35CLProcess 4 to 20mA (100.0), easily user scalable, 3.5 digit
DU-35CLEProcess 4 to 20mA (100.0) with 24V DC excitation, scalable, 3.5 digit
DU-45CLProcess 4 to 20mA (100.00), easily user scalable, 4.5 digit
DU-35PPressure, strain gage and load cell, 4 and 6 wire, 5V DC excitation, Header Selectable Sensitivity 2mV/V, 5mV/V, 10mV/V, 20mV/V, 3.5 digit
DU-35J/KOrder J or K Thermocouple and °C or °F, 3.5 digit
DU-35RTD100Ω platinum RTD, 3 or 4 wire, order °C or °F and 0.1° or 1°, 3.5 digit

Functional Diagram

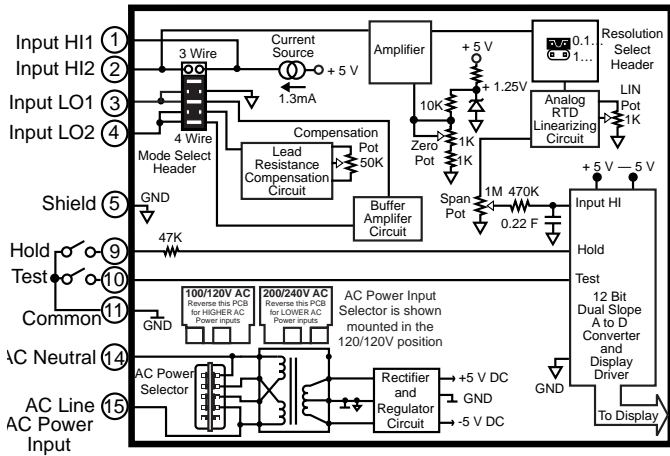

Connector Pinouts Functional Diagram

This meter is supplied with plug-in type screw terminal connectors. The power supply pins (14 & 15) have a unique plug and socket outline to prevent cross connection. (see DU Connectors)

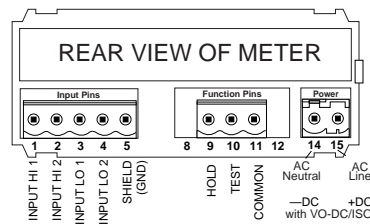

WARNING: AC and DC input signals and power supply voltages can be hazardous. Do Not connect live wires to screw terminal plugs, and do not insert, remove or handle screw terminal plugs with live wires connected.

- Pin 1 - Input Hi 1:** Input from 3 wire/4 wire RTD.
- Pin 2 - Input Hi 2:** Input for 4 wire RTDs. When sensor is a 3 wire RTD, this pin is not used.
- Pin 3 - Input Lo 1:** Input for 3 wire/4 wire RTDs.
- Pin 4 - Input Lo 2:** Input for 3 wire/4 wire RTDs.
- Pin 5 - Shield:** This pin is internally connected to the ground of the internal power supply.
- Pin 9 - Hold Reading:** If this Pin is left unconnected, the meter will operate in a free-running mode. When this pin is connected to the Hold/Test Common Pin 11, the meter will latch up. A/D conversions will continue, but the display will not be updated until Pin 9 is disconnected from the Hold/Test Common pin 11.
- Pin 10 - Display Test:** All numeric display segments will light up when this pin is connected to the Hold/Test Common Pin 11.
- Pin 11 - Hold/Test Common:** The Hold and Display Test Pins have to be connected to this pin to activate their respective functions.
- Pins 14 & 15 - AC Power Input:** These pins are the Power Input pins for the meter. All DU-Series meters sold in North America are pre-configured at the factory for 100/120V AC operation. To re-configure for 200/240V AC operation, simply pull out the AC Power Voltage Selector located directly behind the transformer, turn it around and re-insert it into the socket so that "200/240V AC" is visible. Various other AC/DC power options are available. See Ordering Information for details.

Component Layout

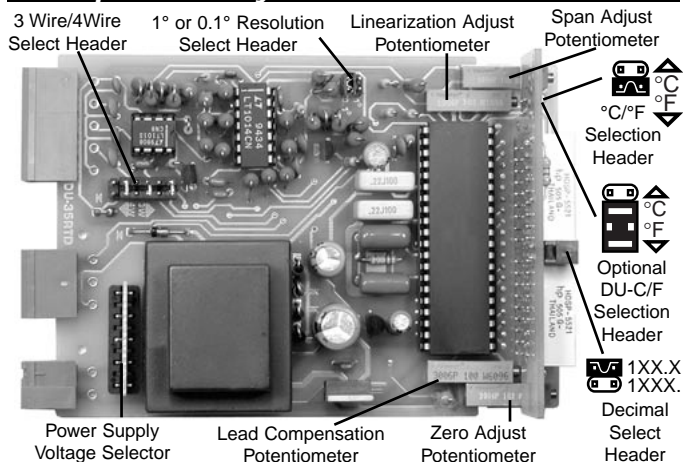

Signal Conditioning Components

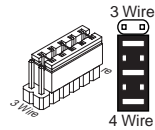

3 WIRE/4 WIRE SELECT Header

This header enables selection of a 3 Wire or 4 Wire RTD input configuration.

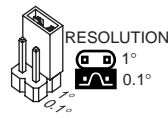

RESOLUTION Select Header

A resolution of 0.1° or 1° is selected by positioning the jumper clip on the Resolution header. Re-calibration is required after any reselection.

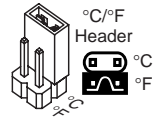

°C/°F Select Header

°C or °F may be selected by positioning the jumper clip on the header. Re-calibration is required after any reselection.

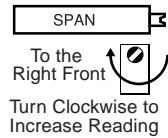

SPAN Potentiometer (Pot)

The SPAN pot is on the right side of the display. Typical adjustment is 20% of the input signal range.

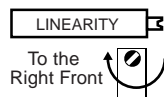

LINEARITY Potentiometer (Pot)

The LINEARITY pot is to the right of the SPAN pot and is used for top end linearity calibration.

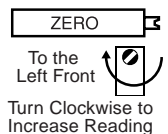

ZERO Potentiometer (Pot)

The ZERO pot is on the left side of the display. Typically it enables the display reading to be offset ±500 count.

Calibration Procedure

- Select a resolution of 0.1° or 1° on the Resolution Select Header. Select the appropriate decimal point on the Decimal Select Header. Select a display of °C or °F on the °C/°F Select Header. Select a 3 or 4 wire input configuration, with the 3 wire/4 wire Select Header. Note: Lead Compensation can only be calibrated in the 3 wire positioning. After calibration, the 4 wire mode can be selected without further calibration.
- Connect an RTD Simulator to the input of the DU-35RTD and calibrate according to the Calibration Table below..

Calibration Table	0.1°C	1°C	0.1°F	1°F
3. Adjust Zero Pot so display matches RTD simulator with output set to:	0.0°C	0°C	0.0°F	0°F
4. Adjust Span Pot so display matches RTD simulator with output set to:	-190.0°C	-190°C	-190.0°F	-190°F
5. Adjust Linearity Pot so display matches RTD simulator with output set to: Repeat Step 4 and 5 until both readings remain constant.	190.0°C	800°C	190.0°F	1470°F
6. Introduce an equal resistance of not more than 50Ω between each input of the RTD simulator and the meter. Adjust the Lead Compensation Pot so display matches RTD simulator with output set to:	190.0°C	800°C	190.0°F	1470°F

The Lead Compensation is calibrated at the factory for lead resistances up to 50Ω each, and usually does not need to be re-calibrated.

- The DU-35RTD meter is now calibrated and ready for use.

Decimal Point Selection

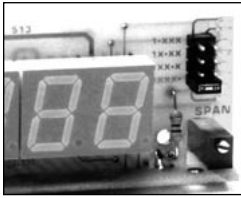

Decimal selection is made on the front of the display board by moving the jumper to the indicated position on the header for the decimal required.

Rear Selection of Decimal Points

An optional output board is available that provides access to all decimal points via a rear PCB edge connector.

Opening Back Panel



To open back panel, insert a flat screwdriver or similar instrument in both slots on the top of the case and pry open. The DU-Series meters slide out from the rear of the case as a complete assembly.

Selecting Power Supply Voltage

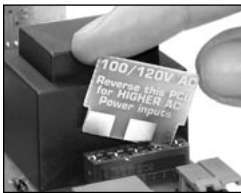

This unique voltage selector PCB displays the operating voltage selected. To change the voltage, disconnect power to the meter. Remove the selector, reverse the selector and fully re-insert it in the socket. This selector is not required for optional power supplies.

DU-Series Connector Options

Plug-in Screw Terminal Connectors are Provided

Input Power Screw Terminal Plug

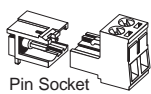

Part Number:
93-PLUG2P-DR

Right-angled Screw Terminal Plug

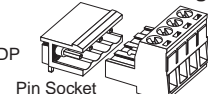

Part Numbers:
93-PLUG2P-DR.....2 pins
93-PLUG3P-DR.....3 pins
93-PLUG4P-DR.....4 pins
93-PLUG5P-DR.....5 pins
93-PLUG6P-DR.....6 pins

Spade Lug pinouts and insulated quick disconnects may still be ordered as an option. P/N.:CN-SPADE.

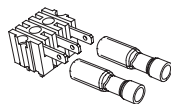

Metal Surround Case Option

The meter's plastic case is made from fire retardant polycarbonate. A metal surround case can be ordered to enhance the meter's fire retardant capabilities and also provide shielding against electromagnetic interference (EMI). The metal case slides over the polycarbonate case and is held firmly in place by spring-type non-return clips. The Metal Surround Case must be factory installed on the polycarbonate case and once installed, it cannot be removed in the field.

With the metal case in place, the meter's standard ratchet-type mounting clips can not be used. Instead a pair of screw-type DIN standard mounting clips are provided, which clip into holes on the side of the metal case and tighten against the rear of the panel. A ground tab on the metal case enables the metal case to be easily connected to the panel ground.

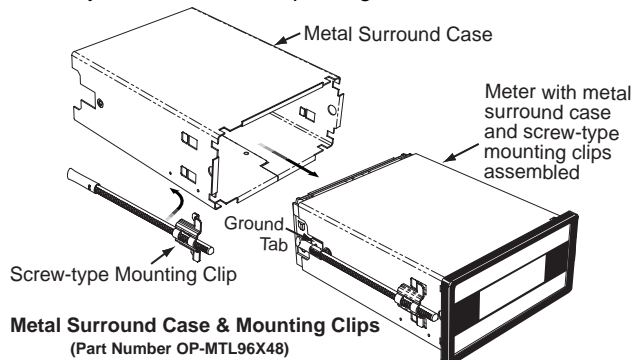

Face Plate Descriptors

AC	Ω	kV	kVAR	m ³ /hr	Hz	RPM
V	mV	min	PF	°F	°C	Cosθ
DC	x10kN	μA	PSIG	mS	kg/cm ²	psi
KW	W	KWH	pH	%	K	kPa
A	mbar	mA	MW	kA	RPS	MWH
mWs	μm	KW/s	I	l/sec	ml	cm
ORP	mm/s	1/min	mm	kg/sec	lbs	kg/hr
FT	bars	min ⁻¹	m/min	Mvars	μV	dB

To customize the face plate, each DU-meter is supplied with a white printed clear adhesive label containing various popular descriptors. Choose the descriptor desired, peel off the adhesive backing and align the descriptor in the center right of the faceplate.

Custom Face Plates



Texmate Produces Thousands of Custom OEM Face Plates

Have Texmate Design and Build a Custom Face Plate to Suit your Next project!

- Custom face plates have a non-recurring artwork charge. A serial number is then assigned to each artwork, to facilitate re-ordering.

- Small Run or One-Off custom face plates incur an installation charge, and are generally printed on a special plastic film, which is then laminated to custom faceplate blanks as required.
- Large Run (250 pieces min): custom face plates are production silk screened, issued a part number, and held in stock for free installation as required by customer orders.
- OEMs may also order Custom Meter Labels, Box Labels Custom Data Sheets and Instruction Manuals.

Optional Display Styles



DU Series Above-Center Display Option



0.8" LED Options available in Lynx Family

To match all display styles, DU-Meters have an optional display and faceplate with the digits positioned above center. (see Display Options)

For 0.8" LEDs in 1/8 DIN cases order Lynx family DX-35 and DX-40 w/ LR or LG displays and input modules that match DU-Series inputs.

Clear Lockable Water-proof Cover

The clear lockable cover is designed to be dust and water proof to NEMA-4X, IP65 standards. The assembly consists of a base and cover with a cam hinge and key-lock fastening mechanism. An O-ring, or neoprene gasket forms a seal between the base and the panel. The cam hinge prevents the cover from closing when opened until pushed closed. The cover has a tapered recess that, when closed, forms a seal with a tapered spigot on the base. A key-lock employs a cam locking device to force the spigot into the recess, ensuring seal integrity. A safety catch keeps the cover closed even when the key is removed, and the keyhole can be used to attach a safety seal clip, preventing unauthorized opening.

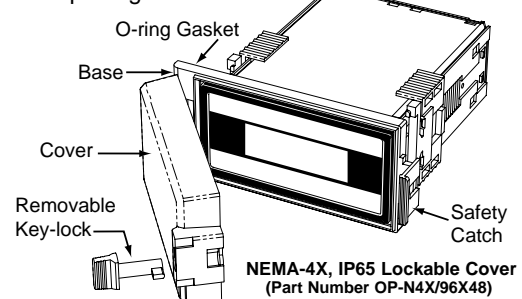

DU Case Dimensions and Panel Cutouts

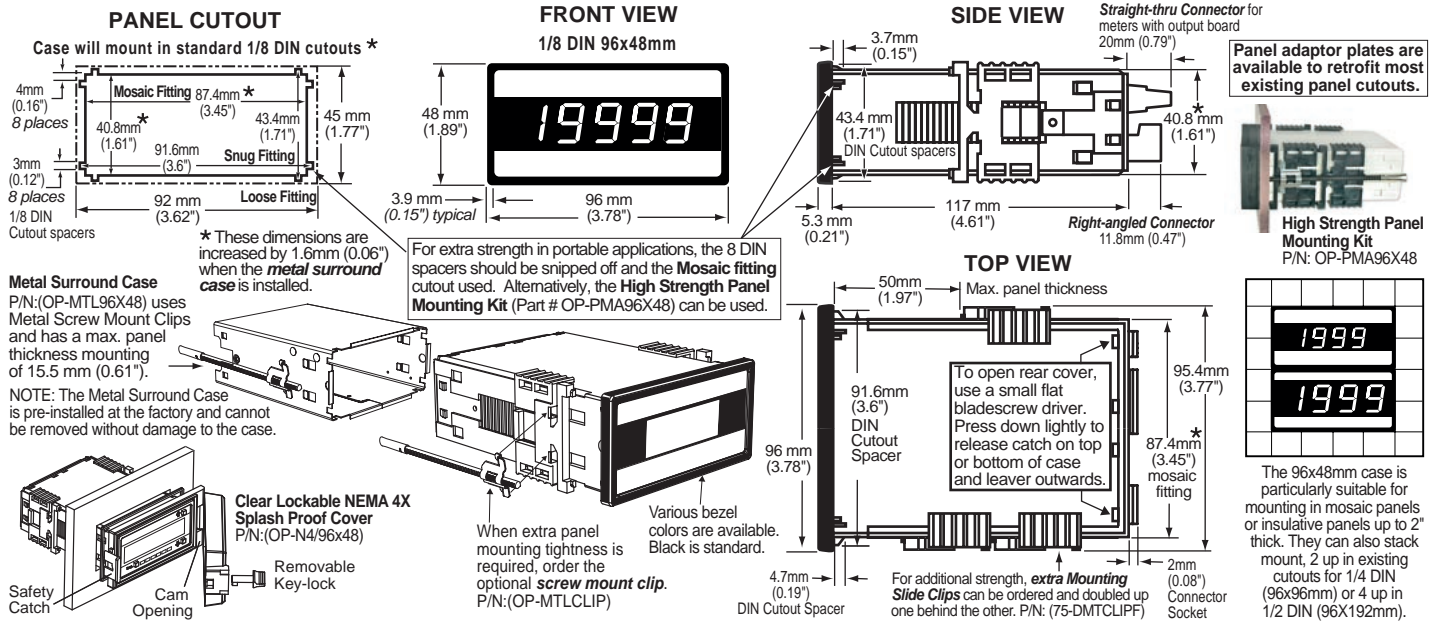

Ordering Information

Standard Options for this Model Number

Part Number	Description	List
► BASIC MODEL NUMBER Includes plug in type screw terminals, standard display and standard power supply unless optional versions are ordered.		
DU-35RTD-F.....DPM, Pt., 100 Ohm in °F, 1° resolution		\$119
DU-35RTD-F.1...DPM, Pt., 100 Ohm in °F, .1° resolution		\$119
DU-35RTD-C.....DPM, Pt., 100 Ohm in °C, 1° resolution		\$119
DU-35RTD-C.1 ..DPM, Pt., 100 Ohm in °C, .1° resolution		\$119
► DISPLAY		
STANDARD.....Red LEDs, 0.56 inch high		./N/C
DU-BRIGHT.....Super bright Red LEDs, 0.56 inch high		\$20
DU-GREEN.....Green LEDs, 0.56 inch high		\$10
DU-GREEN 4.5D ..Dummy Zero Display Option w/ Green LEDs		\$25
DU-RED4.5D.....Dummy Zero Display Option w/ Green LEDs		\$25
DU-35HI/BRT.....Above center position, .56 inch, Bright Red LED		\$30
DU-35HI/GRN.....Above center position, .56 inch, Green LED		\$20
DU-35HI/RED.....Above center position, .56 inch, Red LED		\$10
► POWER SUPPLY		
STANDARD.....100/120 or 200/240VAC User selectable		./N/C
V0-DC/ISO.....Isolated auto-sensing AC/DC 9 to 36 VDC/12 to 24 VAC		\$35
V0-24V.....Isolated transformer 12 VAC or 24 VAC user selectable		\$15
► SPECIAL OPTIONS (Specify Inputs or Outputs & Req. Reading)		
HD-CHANGE.....Range change from the standard input as shown in BOLD type		\$7
DU-C/F.....Header Select °C/°F for DU-35J/K/RTD		\$30

WARRANTY

Texmate warrants that its products are free from defects in material and workmanship under normal use and service for a period of one year from date of shipment. Texmate's obligations under this warranty are limited to replacement or repair, at its option, at its factory, of any of the products which shall, within the applicable period after shipment, be returned to Texmate's facility, transportation charges pre-paid, and which are, after examination, disclosed to the satisfaction of Texmate to be thus defective. The warranty shall not apply to any equipment which shall have been repaired or altered, except by Texmate, or which shall have been subjected to misuse, negligence, or accident. In no case shall Texmate's liability exceed the original purchase price. The aforementioned provisions do not extend the original warranty period of any product which has been either repaired or replaced by Texmate.



995 Park Center Drive • Vista, CA 92081-8397

Tel: 1-760-598-9899 • USA 1-800-839-6283 • That's 1-800-TEXMATE

Fax: 1-760-598-9828 • Email: sales@texmate.com • Web: www.texmate.com

Texmate has facilities in Japan, New Zealand, Taiwan, and Thailand. We also have authorized distributors throughout the USA and in 28 other countries.

Special Options and Accessories

Part Number	Description	List
► ACCESSORIES (Specify Serial # for Custom Artwork Installation)		
75-DBBZ9648F	Black Bezel for 96x48mm Case	\$2
75-DMTCLIPF	Side Slide Brackets (2 pc) - extra set, extra strength	\$2
76-DU35G	Replacement DU Series grey lens for Green LEDs	\$3
76-DU35R	Replacement DU Series red lens for Red LEDs	\$3
76-DUPP/N	Anti-glare protective front lens plate for DU Series	\$3
93-PLUG2P-DP	Extra Screw Terminal Conn., 2 Pin Power Plug	\$2
93-PLUG3P-DR	Extra Screw Terminal Conn., 3 Pin Plug	\$3
CN-SPADE	Spade Lug pinouts and Insulated quick disconnects	\$5
DN+ CAS96X48A	Complete 96x48mm Case with bezel	\$20
OP-DUEXTDP	Option for External Decimal Point	\$20
OP-MCLP96X48	Screw Mounting Clips (2 pc) to screw tighten slide brackets	\$6
OP-MTL96X48	Metal Surround Case includes metal mounting clips	\$16
OP-N4X/96X48	Clear Lockable Water-proof cover, Nema 4X, IP65	\$20
QD-KIT-1	Replacement Crimp-on Quick Disconnects (7 per Set)	\$1
ART-FS-S/D	NRC for Artwork & set-up Custom Faceplate and or Descriptor	\$35
ART-FS-S/D/C	NRC for Artwork & set-up Custom Faceplate and Custom Logo	\$75
ART-FS-001	Produce & Install Custom Faceplate per meter - 1 color no-min	\$10
ART-FS-002	Produce & Install Custom Faceplate per meter - 2 color no-min	\$20
ART-FS-003	Produce & Install Custom Faceplate per meter - 3 color no-min	\$30
ART-FL-001	Custom Faceplate, 250 piece Min. (\$1.00 each) - 1 color	\$250
ART-FL-002	Custom Faceplate, 250 piece Min. (\$1.40 each) - 2 color	\$350
ART-FL-003	Custom Faceplate, 250 piece Min. (\$1.80 each) - 3 color	\$450

Many other options and accessories are available. See full price list for more details. Prices subject to change without notice.

USER'S RESPONSIBILITY

We are pleased to offer suggestions on the use of our various products either by way of printed matter or through direct contact with our sales/application engineering staff. However, since we have no control over the use of our products once they are shipped, NO WARRANTY WHETHER OF MERCHANTABILITY, FITNESS FOR PURPOSE, OR OTHERWISE is made beyond the repair, replacement, or refund of purchase price at the sole discretion of Texmate. Users shall determine the suitability of the product for the intended application before using, and the users assume all risk and liability whatsoever in connection therewith, regardless of any of our suggestions or statements as to application or construction. In no event shall Texmate's liability, in law or otherwise, be in excess of the purchase price of the product.

Texmate cannot assume responsibility for any circuitry described. No circuit patent or software licenses are implied. Texmate reserves the right to change circuitry, operating software, specifications, and prices without notice at any time.

For product details visit www.texmate.com

Local Distributor Address

K-Tech Ph.1847 375 9524

Fx. 1-847 375 9523

www.K-Tech.com meters@k-tech.com

Copyright © 2000 Texmate Inc. All rights reserved.